

HP 83217A

Mobile Station Test Software

User's Guide

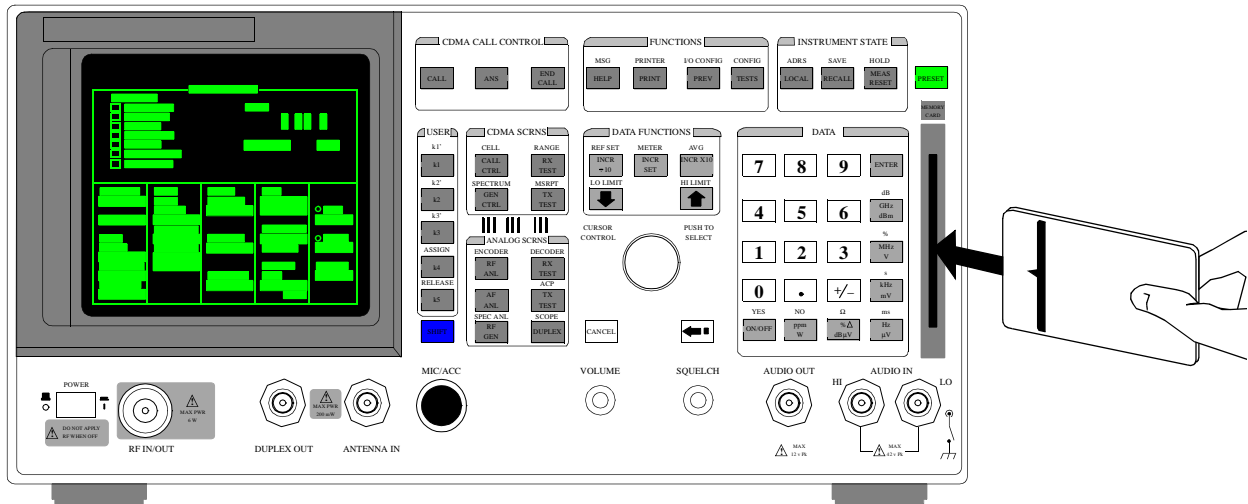

HP Part No. 83217-90001
 Printed in U. S. A.
 August 1999

Rev. E

Copyright © Hewlett-Packard Company 1996

**RESTRICTED
RIGHTS LEGEND**

Use, duplication or disclosure by the U.S. Government is subject to restrictions as set forth in subparagraph (c) (1) (ii) of the Rights in Technical Data and Computer Software clause in DFARS 252.227-7013.

Hewlett-Packard Company
3000 Hanover Street
Palo Alto, CA 9430
U.S.A.

Rights for non-DOD U.S. Government Departments and Agencies are as set forth in FAR 52.227-19(c) (1,2).

Contents

1 Using the Software

To Load a Test Procedure 16

To Connect a Mobile Station 21

AMPS Mobile Station 21

CDMA Mobile Station 23

To Run a Test Procedure 25

To Pause or Stop a Test Procedure 29

To pause a Test Procedure 29

To continue a paused Test Procedure 29

To Stop a Test Procedure 29

To Exit and Re-enter a Test Procedure 30

Contents

2 Setting Up the Software's Execution Conditions

To Configure Software Execution Conditions 38

If Unit-Under-Test Fails: 40

Test Procedure Run Mode: 41

Autostart Test Procedure on Power-Up: 42

3 Customizing a Test Procedure

To Specify Channel Information 44

Cell Channel 49

Test? 50

Prime? 51

Options 52

To Change Test Parameters 53

To Change the Order of Tests 58

Inserting a Test Into a Test Procedure 59

All Chans? 63

Deleting A Test From a Test Procedure 64

To Change Pass/Fail Limits 68

Check 74

To Save a Customized Test Procedure 75

Enter Description for New Procedure: 80

Deleting A Test Procedure 84

Securing (and Un-securing) A Test Procedure 90

4 Setting Up the Test Set for External Devices

To Configure an External Printer 104

Output Results To: 106

Output Results For: 107

Output Heading: 108

Unsupported Printers 109

To Configure a Programmable Power Supply 127

Using an External PC or Terminal 133

Configuring the Test Set for Terminal or PC Operation 133

Configuring the Test Set's Serial I/O Port 134

Configuring an External PC 136

Configuring a Terminal Emulator 139

Configuring a Terminal 144

Contents

5 Setting Up the Test Set for Data Collection

To Set Up for Data Collection 146

Mass Storage Addresses 152

To Collect Data (Saving Test Results) 154

To Retrieve Test Results 156

To Initialize a Memory Card (DOS Format) 167

To Initialize a Memory Card (LIF Format) 172

Contents

6 Test Set Overview

TESTS (Main Menu) Screen Overview	179
LOAD TEST PROCEDURE: Field Descriptions	179
CUSTOMIZE TEST PROCEDURE: Field Descriptions	180
SET UP TEST SET: Field Descriptions	180

7 Reference (Alphabetical)

Escape Sequences for HP Printers 183

File Types and Sizes 184

Recommended File System 184

Media Formatting 184

The Options Field 184

HP-IB Control Annunciators 186

Interactions Between the Test?, Prime?, and All Chans? Fields 187

Memory Cards 190

Memory Card Types 191

Memory Card Storage Space 192

The Tests Subsystem 193

Tests Subsystem File Descriptions 194

Serial Port Information 196

Serial Port 9 196

Serial Port 10 196

USER Keys (K1-K5) 197

Contents

8 Problem Solving

Data Collection Is Not Working 200

Test Procedure Won't Run 201

Test Results are Unexpected 202

Contents

9 Error Messages

Error Messages Overview 204

Contents

Glossary 207

Contents

Index 213

Contents

Using the Software

This chapter provides information on how to load and run the software using the factory default settings.

To Load a Test Procedure

When a test procedure's file name is selected, the information contained in the test procedure file is automatically loaded into the Tests Subsystem (for more information about the Tests Subsystem, see "[The Tests Subsystem](#)" on page 193). The **Description** field is updated with a brief description of the test procedure. The [following example](#) shows how to load a test procedure from a memory card.

1. Activate the Tests Subsystem.

- Press the PRESET key.
- Insert the memory card (for this example).
- Press the TESTS key.

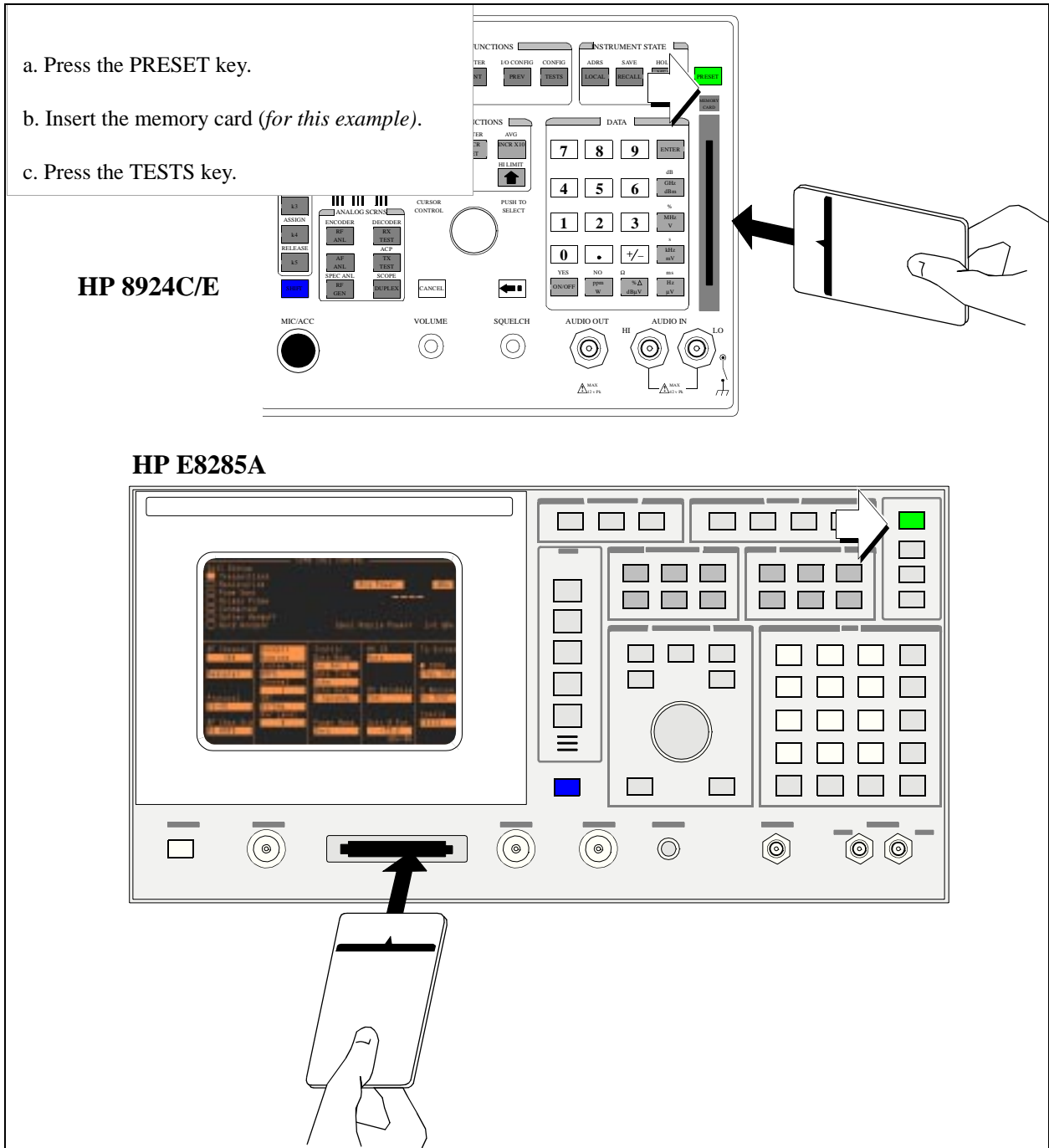

2. Select the location where the test procedure file is stored.

a. Position the cursor at the **Select Procedure Location:** field and select it.

b. In the **Choices:** menu displayed in the lower right corner of the screen, position the cursor at **Card** (for this example) and select it.

TESTS (Main Menu)

a procedure to load.

LOAD TEST PROCEDURE:
Select Procedure Location:
Select Procedure Filename: Library: Program:
Description:
CUSTOMIZE TEST PROCEDURE: SET UP TEST SET:

1 Run Test
2 Continue
4 Help

Choices:
■ Card
ROM
RAM
Disk

3. Select a test procedure filename.

- a. Position the cursor at the **Select Procedure Filename:** field and select it.
- b. In the **Choices:** menu displayed in the lower right corner of the screen, position the cursor at the desired test procedure and select it.

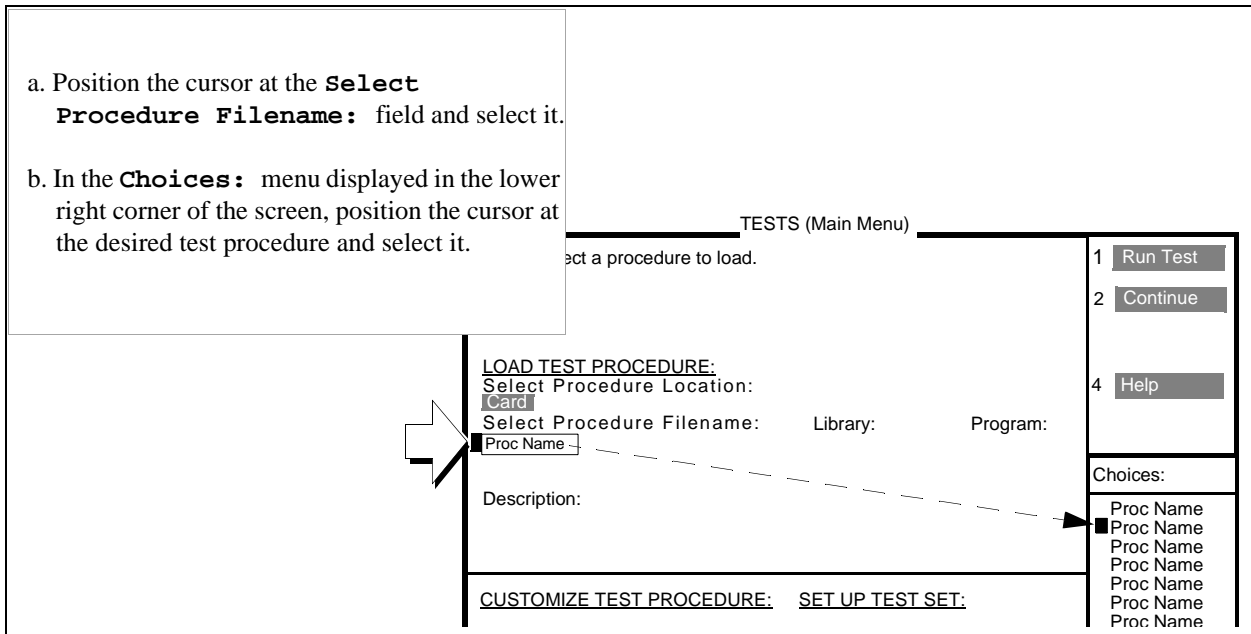

4. Verify that the test procedure is loaded.

The software title is displayed here.

The procedure name, library file name, and program location are displayed here.

A description of the selected procedure is displayed here.

TESTS (Main Menu)

HP 83217A Software Name

LOAD TEST PROCEDURE:
Select Procedure Location:

Card		
Select Procedure Filename:	Library:	Program:
Proc Name		

Description:
Factory or User Defined Procedure Description

CUSTOMIZE TEST PROCEDURE: SET UP TEST SET:

Freq	Exec
Parm	Cnfg
Seqn	Print
Spec	IBASIC
Proc	IBASIC Cntrl

1 Run Test

2 Continue

4 Help

To Screen

CDMA
CALL CNTL

Analog
RX TEST

Config
TESTS

To Connect a Mobile Station

"AMPS Mobile Station" on page 21
"CDMA Mobile Station" on page 23

AMPS Mobile Station

Numerous cables and connectors are required to connect the mobile-station-under-test (MSUT) with the Test Set.

Determining Path Loss

See the procedure for "Determining Path Loss" in the *HP 8924C Application Guide*.

Cable Connections

- If any audio testing is to be done on the MSUT, the audio input (microphone input) to MSUT and the audio output (speaker output) from the MSUT must be connected to the Test Set. If no audio testing is to be done, only the antenna needs to be connected to the Test Set.

Figure 1 shows a typical example of connecting an MSUT to the Test Set. Many of today's small, handheld MSUTs require special fixtures, available from the mobile station's manufacturer. These fixtures provide access to the antenna, dc power, audio input and audio output connection on the MSUT.

Table 1 Cables and Connectors

Reference #	Description	Purpose	Quantity Needed	Part Number
1	BNC(f) to Type N(m) adapter	Adapt BNC cable to RF IN/OUT	1	HP 1250-0780
2	Manufacturer's Special Fixture	Provide access to antenna, audio input, audio output and dc power	1	MSUT dependent
3	HP-IB Interface cable, 1 meter	Test Set HP-IB connector to power supply HP-IB connector	1	HP 10833A

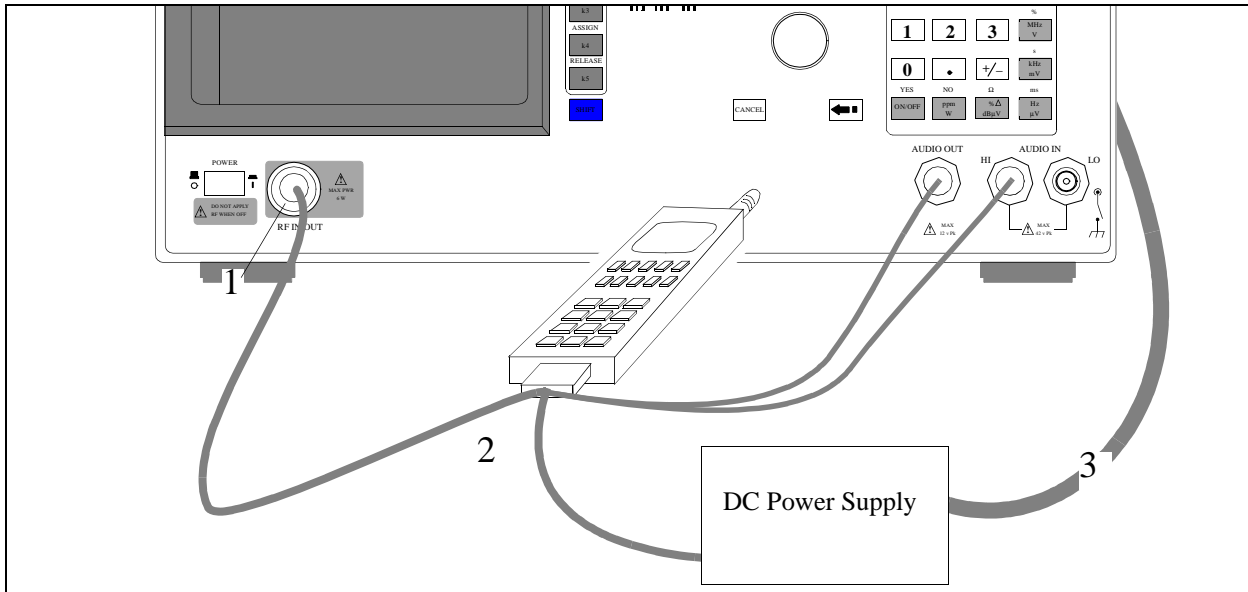

Figure 1

AMPS Mobile Station To Test Set Connections

Audio Connections are used only for the following tests:

- TEST_05 - TXA Modulation Deviation Limiting
- TEST_06 - TXA Audio Frequency Response
- TEST_07 - TXA Audio Distortion
- TEST_09 - TXA FM Hum and Noise
- TEST_12 - TXA Compressor Response
- TEST_14 - RXA Expander
- TEST_15 - RXA Audio Frequency Response
- TEST_16 - RXA Audio Distortion
- TEST_17 - RXA Hum and Noise
- TEST_18 - RXA SINAD
- TEST_23 - TXA Quick General
- TEST_24 - RXA Quick General

The method of making the audio connections is dependent on the MSUT being tested. Some manufacturers provide a method for audio signal breakout while others require that the audio lines to the handset be tapped or an acoustic coupler be used on the handset. Consult the mobile manufacturer for the correct method of audio connection.

CDMA Mobile Station

Numerous cables and connectors are required to interface the mobile-station-under-test (MSUT) with the Test Set.

Calibrating Cable Loss

See the procedure for “Determining Path Loss” in the *HP 8924C Application Guide*.

Cable Connections

Figure 2 shows a typical example of connecting an MSUT to the Test Set. Many of today's small, handheld MSUTs require special fixtures, available from the mobile station's manufacturer. These fixtures provide access to the antenna and dc power connections on the MSUT.

NOTE: No audio testing is available for CDMA mobile stations.

Table 2 Cables and Connectors

Reference #	Description	Purpose	Quantity Needed	Part Number
1	BNC(f) to Type N(m) adapter	Adapt BNC cable to RF IN/OUT	1	HP 1250-0780
2	Manufacturer's Special Fixture	Provide access to antenna and dc power	1	MSUT Dependent
3	HP-IB Interface cable, 1 meter	Test Set HP-IB connector to power supply HP-IB connector	1	HP 10833A

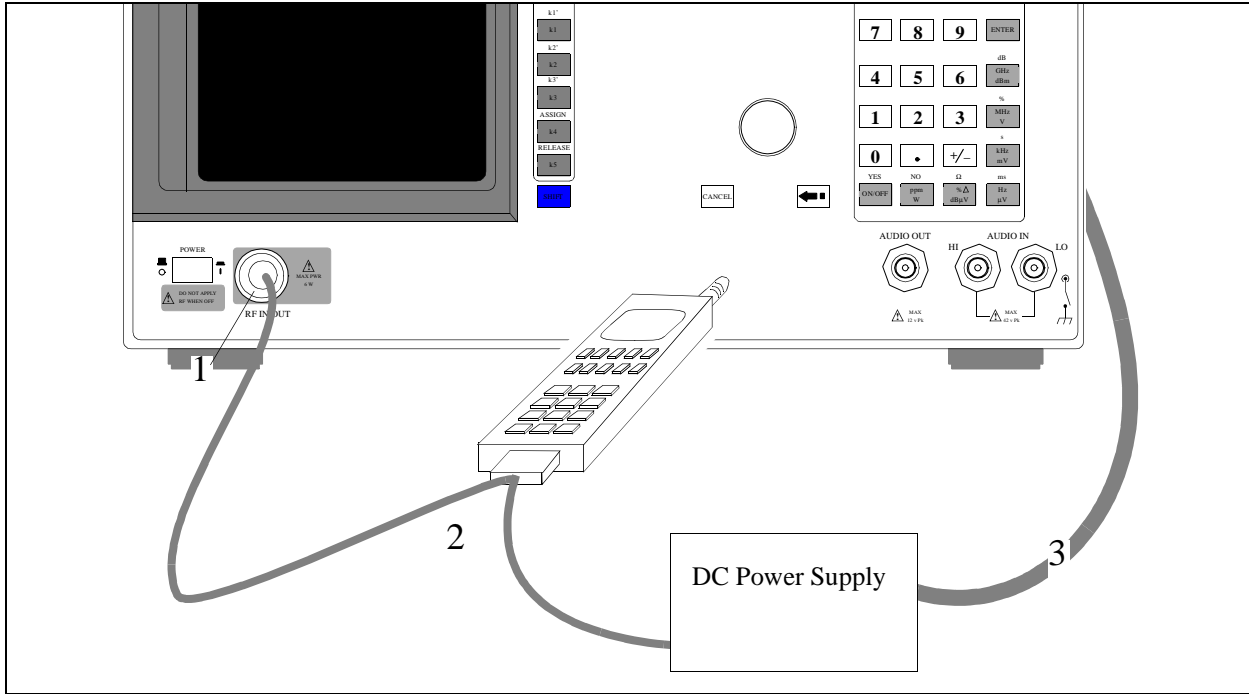

Figure 2 CDMA Mobile Station To Test Set Connections

NOTE: No audio testing is available for CDMA mobile stations.

To Run a Test Procedure

The process for running a test procedure is shown in the [following procedure](#).

The software memory card must be in the memory card slot the first time a procedure is run. After a procedure is run, the program code file for the procedure will remain in memory after a power-down/power-up cycle unless it is manually deleted or a new program is loaded.

1. Load a test procedure.

- a. If a test procedure file is already loaded, go to step 2.
- b. If a test procedure is not loaded in the Test Set's memory, perform the procedure **"To Exit and Re-enter a Test Procedure"** on page 30, then return to this procedure, step 2.

HP 8924C/E

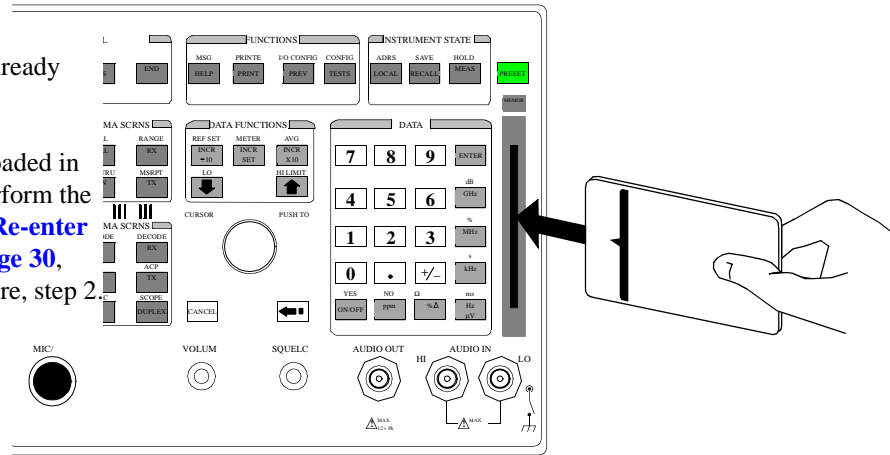

HP E8285A

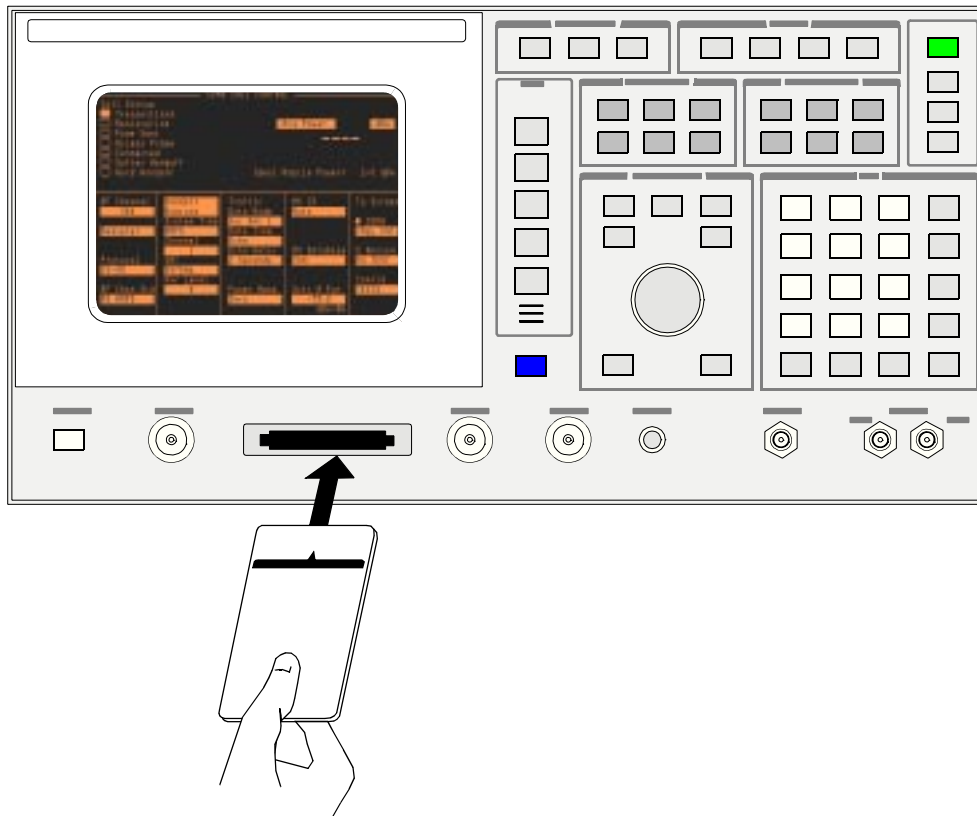

2. Select the TESTS (Main Menu) screen.

a. Press the TESTS key to access to the TESTS (Main Menu) screen.

TESTS (Main Menu)

17A Software Name

1 Run Test

2 Continue

4 Help

LOAD TEST PROCEDURE:
 Select Procedure Location:
 Card
 Select Procedure Filename: Library: Program:
 Proc Name

Description:
 Factory or User Defined Procedure Description

CUSTOMIZE TEST PROCEDURE: **SET UP Test Set:**

<table style="width: 100%; border-collapse: collapse;"> <tr><td style="border: 1px solid black; padding: 2px;">Freq</td><td>Channel Information</td></tr> <tr><td style="border: 1px solid black; padding: 2px;">Parm</td><td>Test Parameters</td></tr> <tr><td style="border: 1px solid black; padding: 2px;">Seqn</td><td>Order of Tests</td></tr> <tr><td style="border: 1px solid black; padding: 2px;">Spec</td><td>Pass/Fail Limits</td></tr> <tr><td style="border: 1px solid black; padding: 2px;">Proc</td><td>Save/Delete Procedure</td></tr> </table>	Freq	Channel Information	Parm	Test Parameters	Seqn	Order of Tests	Spec	Pass/Fail Limits	Proc	Save/Delete Procedure	<table style="width: 100%; border-collapse: collapse;"> <tr><td style="border: 1px solid black; padding: 2px;">Exec</td><td>Execution Cond</td></tr> <tr><td style="border: 1px solid black; padding: 2px;">Cnfg</td><td>External Devices</td></tr> <tr><td style="border: 1px solid black; padding: 2px;">Print</td><td>Printer Setup</td></tr> <tr><td style="border: 1px solid black; padding: 2px;">IBASIC</td><td>IBASIC Cntrl</td></tr> </table>	Exec	Execution Cond	Cnfg	External Devices	Print	Printer Setup	IBASIC	IBASIC Cntrl
Freq	Channel Information																		
Parm	Test Parameters																		
Seqn	Order of Tests																		
Spec	Pass/Fail Limits																		
Proc	Save/Delete Procedure																		
Exec	Execution Cond																		
Cnfg	External Devices																		
Print	Printer Setup																		
IBASIC	IBASIC Cntrl																		

To Screen

CDMA
CALL CNTL

Analog
RX TEST

Config
TESTS

3. Select the Run Test softkey.

a. Press USER key K1, or position the cursor next to **Run Test** and select it. The TESTS (IBASIC Controller) screen will be displayed and the program code file will be loaded.

b. Verify the results of the test.

TESTS (Main Menu)

17A Software Name

PROCEDURE: _____

Location: _____

Filename: Library: Program: _____

CUSTOMIZE TEST PROCEDURE: SET UP Test Set:

Freq	Channel Information	Exec	Execution Cond
Parm	Test Parameters	Cnfg	External Devices
Seqn	Order of Tests	Print	Printer Setup
Spec	Pass/Fail Limits	IBASIC	IBASIC Cntrl
Proc	Save/Delete Procedure		

To Screen

CDMA
CALL CNTL

Analog
RX TEST

Config
TESTS

TESTS (IBASIC Controller)

	1	Yes
	2	No
	3	P/F
	4	

When the K1 (**Run Tests**) softkey is selected the Test Set firmware checks RAM memory to see if the code file associated with the test procedure is loaded into memory. If it is not, the code file is loaded. If the code file is loaded, the firmware checks the revision of the code file loaded into memory against the revision of the code file on the memory card. If the revision of the code file on the memory card is newer than the revision of the code file in RAM memory, the firmware will load the newer revision. It takes approximately 15 seconds to load the software.

28 S:\HP83217A\USRGUIDE\BOOK\Chapters\2usesw.fb

To Pause or Stop a Test Procedure

To pause a Test Procedure

Press the CANCEL key to pause a test procedure.

To continue a paused Test Procedure

Press the TESTS key, then press K1 (**Continue**) to continue a paused test procedure.

CHANGING SETTINGS WHILE PAUSED

If you make changes to instrument settings while the program is paused, subsequent operation may be unpredictable. Error messages may or may not be displayed. See "[To Exit and Re-enter a Test Procedure](#)" on page 30.

To Stop a Test Procedure

Press and release the SHIFT key, then press the CANCEL key. This performs an IBASIC RESET operation and stops the test procedure.

To Exit and Re-enter a Test Procedure

If you need to perform Test Set operations not provided by software, you may exit and re-enter a currently executing test procedure.

The recommended procedure for exiting and re-entering a test procedure is as follows:

NOTE:

Do not press the analog RX TEST or TX TEST keys to exit a currently executing test procedure. Selecting the RX TEST or TX TEST screen causes internal signal paths to be re-configured.

1. Pause the currently executing test procedure.

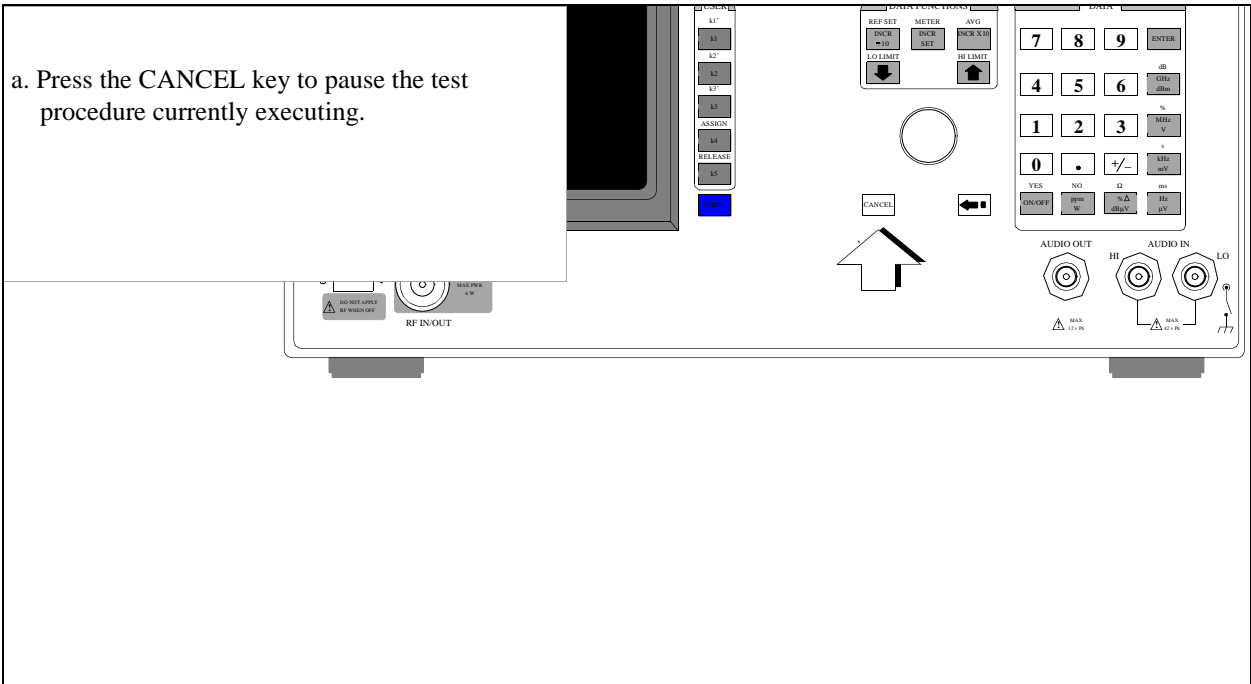

2. Exit the Tests Subsystem.

- a. Press the DUPLEX key.
- b. Verify that the DUPLEX TEST screen is displayed.

HP 8924C/E

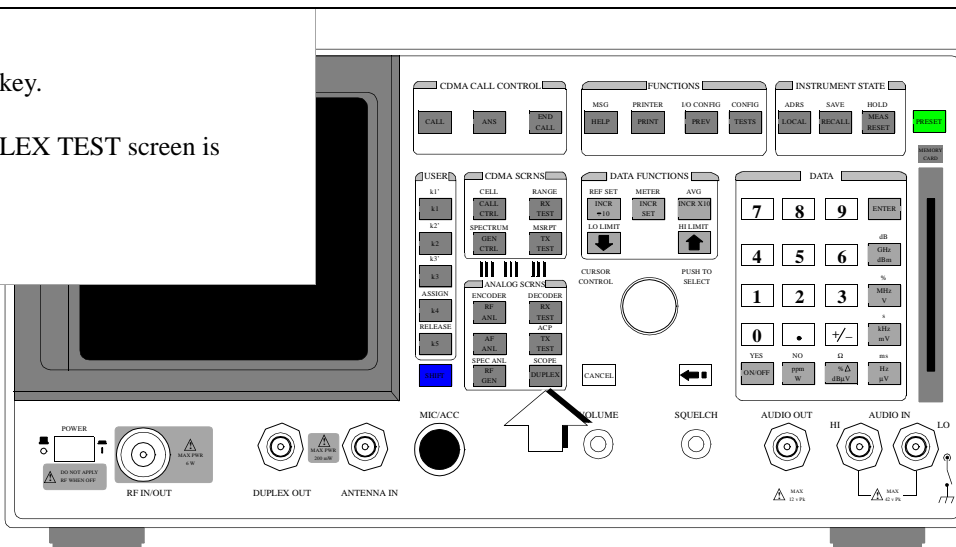

HP E8285A

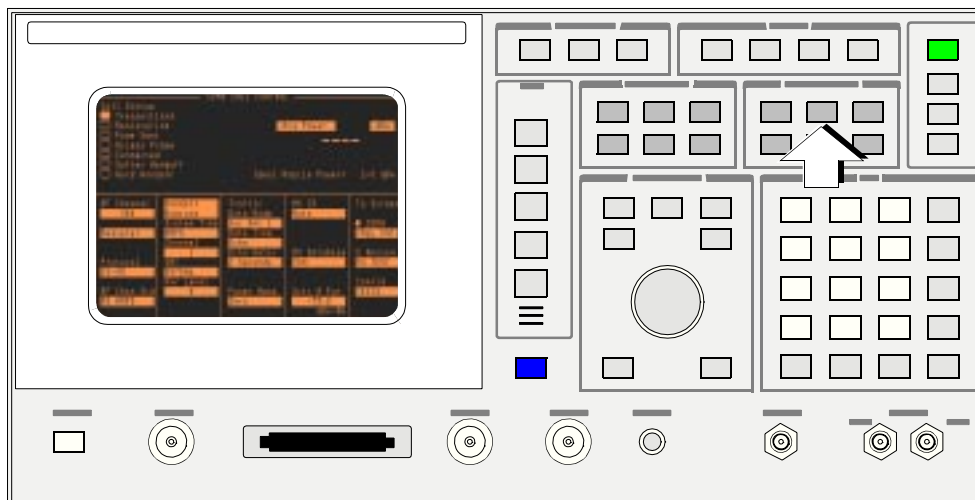

3. Save the Test Set's configuration to a storage register.

- Press and release the SHIFT key, then press the RECALL key to access the SAVE function.
- Using the list of characters in the **Choices:** menu, enter a register name or number.
- Select **Done** from the **Choices:** menu.

HP 8924C/E

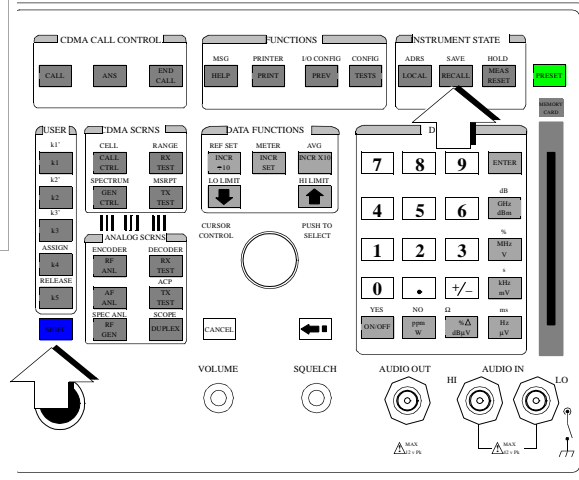

HP E8285A

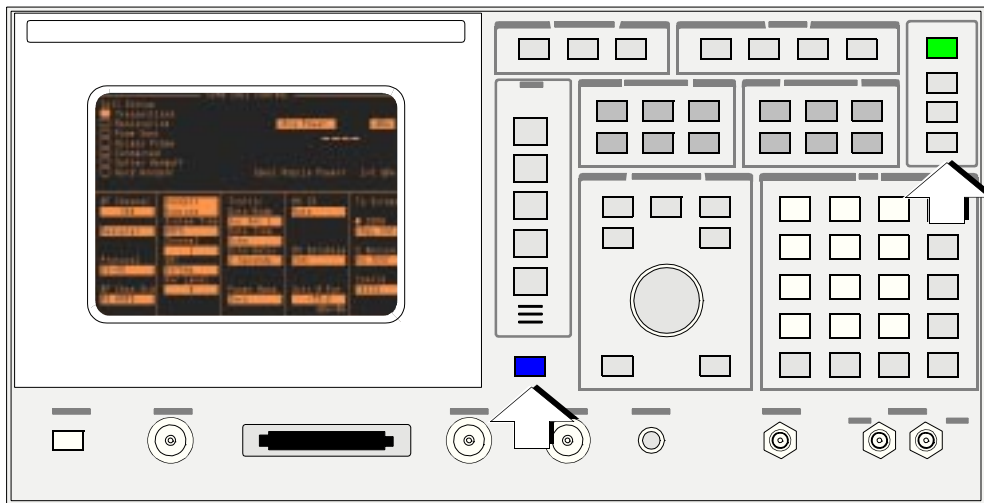

4. Perform any operations that need to be performed before re-entering the software routine.

5. Recall the Test Set's previous configuration.

- a. Press the RECALL key.
- b. In the **Recall:** menu displayed in the lower right corner of the screen, position the cursor next to the name or number of the storage register saved in step 3 and select it.

HP 8924C/E

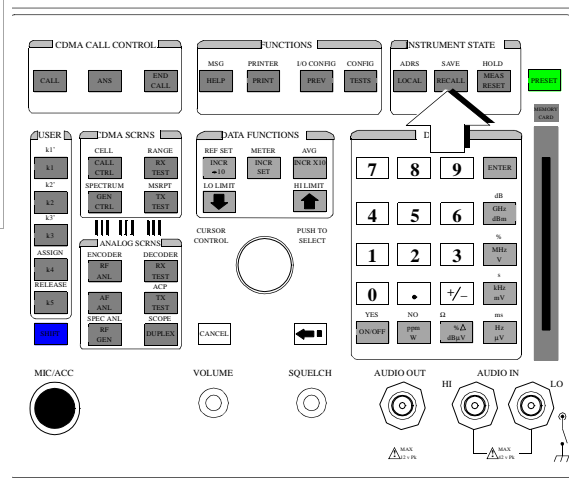

HP E8285A

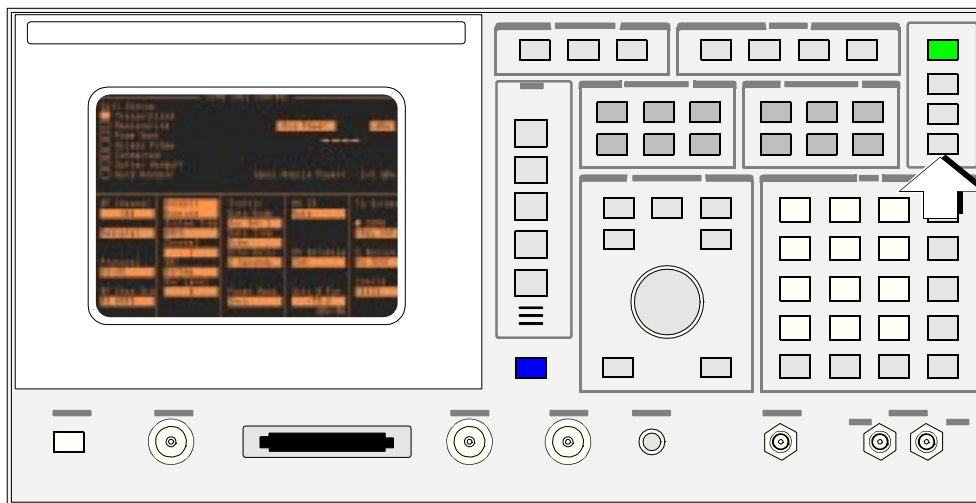

6. Re-start the test procedure.

- a. Press the TESTS key.
- b. Press K2 (**Continue**).

HP 8924C/E

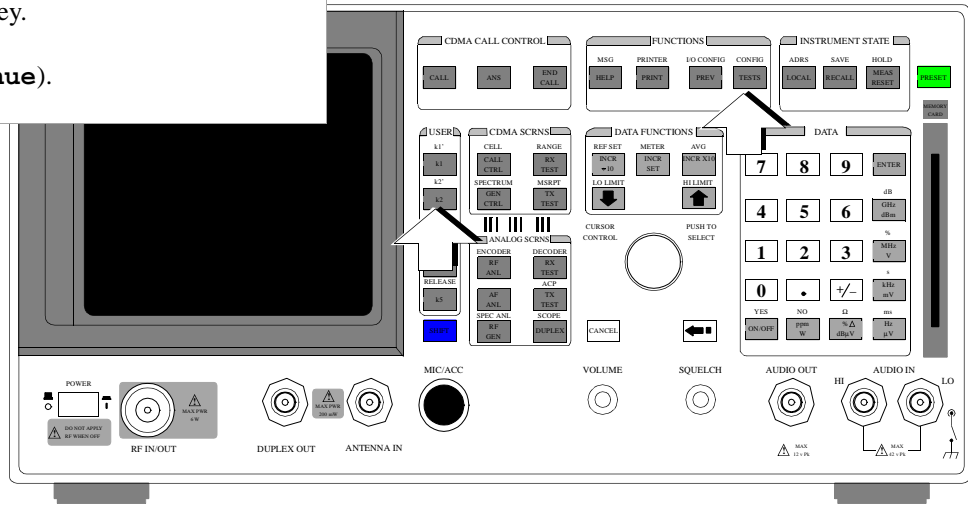

HP E8285A

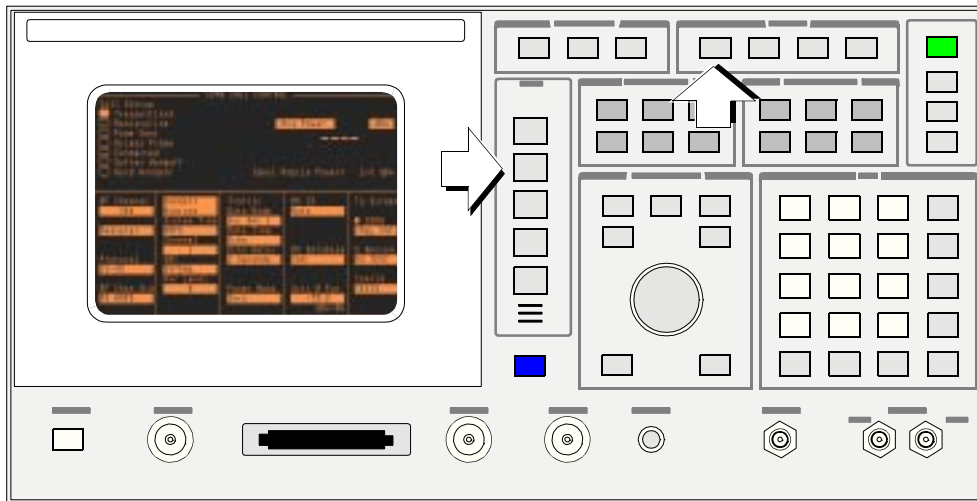

Chapter 1, Using the Software
To Exit and Re-enter a Test Procedure

Setting Up the Software's Execution Conditions

The software's execution conditions determine what the test procedure does when a test fails, whether the test procedure performs tests singly or continuously, and whether or not a test procedure starts automatically when instrument power is turned on.

The software's execution conditions specified in the TESTS (Execution Conditions) screen are not retained after a power-down/power-up cycle, and will return to their default settings.

To Configure Software Execution Conditions

The [following example](#) shows how to select the fields for setting the software execution conditions.

1. From the TESTS (Main Menu) screen select the screen for changing the software execution conditions.

a. Position the cursor at the **Execution Cond** field and select it.

b. Verify that the TESTS (Execution Conditions) screen appears.

TESTS (Main Menu)

P 83217A Software Name

TEST PROCEDURE:
Procedure Location:
Procedure Filename:
Library:
Program:

Description:

CUSTOMIZE TEST PROCEDURE:
SET UP Test Set:

Freq
Parm
Seqn
Spec
Proc

Channel Informati
Test Parameters
Order of Tests
Pass/Fail Limits
Save/Delete Procedure

Exec
Cnfg
Print
IBASIC

Execution Cond
External Devices
Printer Setup
IBASIC Cntrl

TESTS (Execution Conditions)

Output Results To:
CRT/Printer

Output Results For:
All/Failures

Output Heading:

If Unit-Under-Test Fails:
Continue/Stop

Test Procedure Run Mode:
Continuous/Single Step

Autostart Test Procedure on Power-Up:
Off/On

1 Run Test

2 Continue

4 Help

5 Main Menu

To Screen

CDMA
CALL CNTL

Analog
RX TEST

Config
TESTS

2. Select whether to stop or continue on failures.

a. Position the cursor at the **If Unit-Under-Test Fails:** field and select **Continue** or **Stop**.

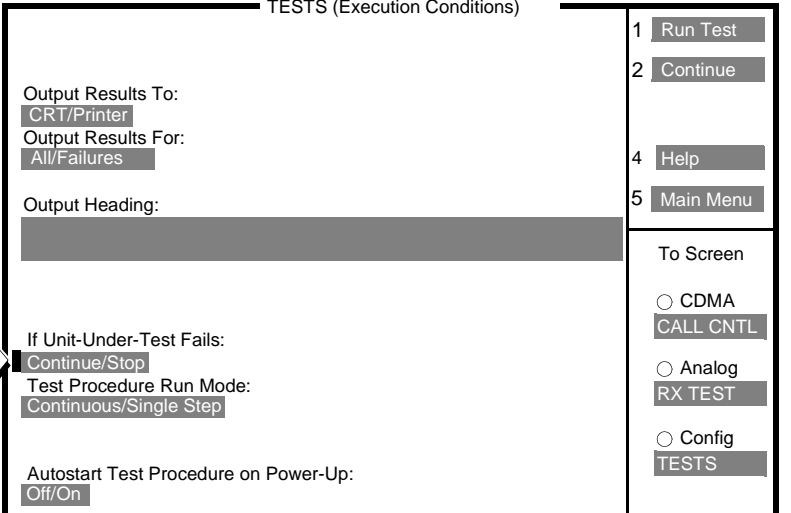

TESTS (Execution Conditions)

Output Results To:
CRT/Printer

Output Results For:
All/Failures

Output Heading:

If Unit-Under-Test Fails:
Continue/Stop

Test Procedure Run Mode:
Continuous/Single Step

Autostart Test Procedure on Power-Up:
Off/On

1 Run Test
2 Continue
4 Help
5 Main Menu

To Screen
 CDMA
CALL CNTL
 Analog
RX TEST
 Config
TESTS

If Unit-Under-Test Fails:

You can select either **Continue** or **Stop**. Default: **Continue**

If you select **Stop**, testing will stop when a measurement result fails the pass/fail limits.

If you select **Continue**, testing will continue when a measurement result fails the pass/fail limits.

3. Select whether to pause the test procedure after each measurement.

a. Position the cursor at the **Test Procedure Run Mode:** field and select Continuous or Single Step.

TESTS (Execution Conditions)

Output Results To:
CRT/Printer

Output Results For:
All/Failures

Output Heading:
[Redacted]

If Unit-Under-Test Fails:
Continue/Stop

Test Procedure Run Mode:
Continuous/Single Step

Autostart Test Procedure on Power-Up:
Off/On

1 Run Test
2 Continue
4 Help
5 Main Menu
To Screen
 CDMA
CALL CNTL
 Analog
RX TEST
 Config
TESTS

Test Procedure Run Mode:

You can select either Continuous or single step. Default: Continuous

The setting of this field will determine if the program pauses between each measurement in each test, or runs through all measurements in all tests.

If you select single step, program execution will pause after a comparison is made between a measurement result and its pass/fail limits. You can continue from the paused state by pressing K2 (Continue).

If you select Continuous, the program will run through all measurements in all tests without pausing.

4. Select whether to autostart a test procedure.

a. Position the cursor at the **Autostart Test Procedure** on **Power-Up:** field and select **Off** or **On**.

TESTS (Execution Conditions)

Output Results To:

Output Results For:

Output Heading:

If Unit-Under-Test Fails:

Test Procedure Run Mode:

Autostart Test Procedure on Power-Up:

1

2

4

5

To Screen

CDMA

Analog

Config

Autostart Test Procedure on Power-Up:

You can select either **On** or **Off**. Default: **Off**

You can configure the Test Set to automatically start a test procedure when the Test Set is powered on.

If you select **On**, when the Test Set's power is turned on, the Test Set will attempt to run the test procedure currently loaded in its memory. If a code file associated with the test procedure is not already loaded into the Test Set's RAM memory, the Test Set will attempt to load the code file. If the Test Set cannot load the code file, the autostart test procedure is terminated and the CDMA CALL CONTROL screen is displayed.

Customizing a Test Procedure

This chapter provides information on how to customize the software to your individual needs and specific requirements.

To Specify Channel Information

The TESTS (Channel Information) screen is used to enter the channel numbers that the mobile station will be tested on. Each time the Run Test softkey is selected, the test sequence (see "To Change the Order of Tests") is performed one time for each channel¹.

NOTE:

Regarding path losses, it is necessary to account for any external cables or pads (attenuators) connected to the test system. There are two such losses: forward and reverse. (If the test software includes Option 001, the screen entry also allows for compensating for path losses when the RF link between the cellular phone and the test system is accomplished via antennas.) The loss is compensated for in power measurements and in signal generator level settings on the test system. Two fields per channel are used to enter the path losses in the TESTS (Channel Information) screen. These fields are: Fwd Loss dB, and Rev Loss dB.

In any of the following conditions, enter the forward path loss in the Fwd Loss dB field and the reverse loss in the Rev Loss dB field in the TESTS (Channel Information) screen. Enter only positive numbers for path loss.

If the test software includes Option 001 and parameter 22 is set to YES, the firmware handles the correction to compensate for the difference between the forward and reverse path losses.

If the test software includes Option 001 and parameter 22 is set to NO, or if the test software includes Option 004, the software computes the correction to compensate for the difference between the forward and reverse path losses.

Channel numbers that correspond to frequencies in channel standards other than MS AMPS must be entered with a code letter appended to the end of the number. For example:

Cell Channel 525P

would be interpreted by the software as channel 525 in the US PCS² channel standard table.

See "Cell Channel" on page 49 for a listing of all channel number code letters.

1. Tests are performed only on the channels that have "Yes" selected in the Test? column on the TESTS (Channel Information) screen.
2. PCS testing is available only with HP 83217A Option 004

For HP 83217A Option 004 software, which includes PCS frequency band testing, the software will scan the entries on the TESTS (Channel Information) screen each time the Run Test softkey is selected to determine which frequency bands will be involved in the upcoming test. This is accomplished by checking channel number code letters. If necessary, channel power calibration will be performed to ensure that all test frequencies have accurate calibration data for power measurements.

For HP 83217A Option 004 software, the first channel entry will be used to set up the initial channel standard and to make a CDMA call. The test sequence displayed on the TESTS (Order of Tests) screen will then be run with the call on the first channel number. After the first test sequence, the software will attempt to handoff to the next channel number and repeat the test sequence. If a channel number corresponding to a different frequency band is encountered during testing, the present call will be terminated. The software will configure the Test Set to operate in the desired frequency band, and a new call will be initiated.

NOTE:

If both PCS and cellular band channels are entered in the table, the software will control the Test Set to perform Channel Power Calibration on both bands before starting the test sequence. This will take considerably more time than calibrating over one frequency band.

The [following example](#) shows how to specify the channels to test.

1. Load a test procedure.

- a. If a test procedure is already loaded, go to step 2.
- b. If a test procedure is not loaded in the Test Set's memory, perform the procedure on ["To Exit and Re-enter a Test Procedure"](#) on page 30, then return to this procedure, step 2.

HP 8924C/E

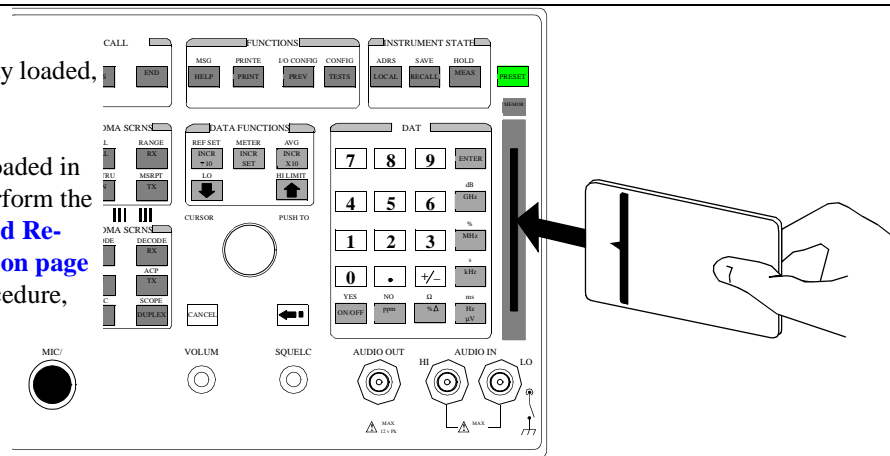

HP E8285A

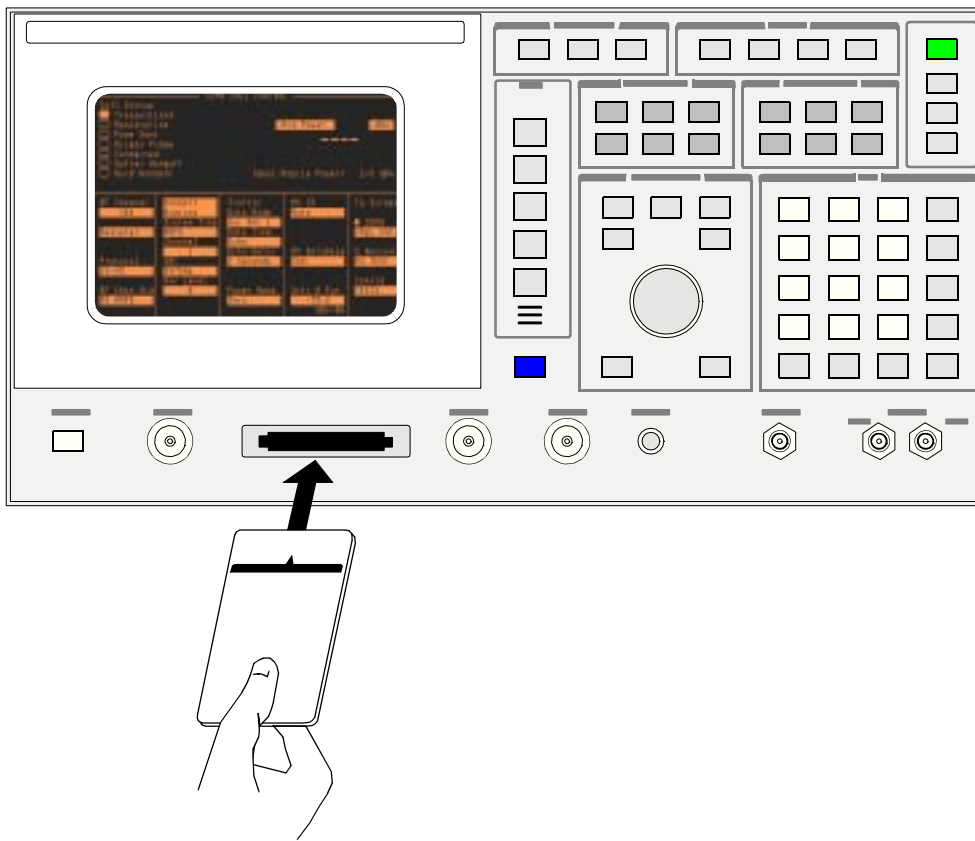

2. Select the screen for specifying channel information.

a. Position the cursor at the **Channel Information** field and select it.

b. Verify that the TESTS (Channel Information) screen appears.

TESTS (Main Menu)

P 83217A Software Name

TEST PROCEDURE:
Procedure Location:

Procedure Filename: Library: Program:

Description:

CUSTOMIZE TEST PROCEDURE: SET UP TEST SET:

<table style="width: 100%; border-collapse: collapse;"> <tr><td style="border: 1px solid black; padding: 2px;">Freq</td><td>Channel Information</td></tr> <tr><td style="border: 1px solid black; padding: 2px;">Parm</td><td>Test Parameters</td></tr> <tr><td style="border: 1px solid black; padding: 2px;">Seqn</td><td>Order of Tests</td></tr> <tr><td style="border: 1px solid black; padding: 2px;">Spec</td><td>Pass/Fail Limits</td></tr> <tr><td style="border: 1px solid black; padding: 2px;">Proc</td><td>Save/Delete Procedure</td></tr> </table>	Freq	Channel Information	Parm	Test Parameters	Seqn	Order of Tests	Spec	Pass/Fail Limits	Proc	Save/Delete Procedure	<table style="width: 100%; border-collapse: collapse;"> <tr><td style="border: 1px solid black; padding: 2px;">Exec</td><td>Execution Cond</td></tr> <tr><td style="border: 1px solid black; padding: 2px;">Cnfg</td><td>External Devices</td></tr> <tr><td style="border: 1px solid black; padding: 2px;">Print</td><td>Printer Setup</td></tr> <tr><td style="border: 1px solid black; padding: 2px;">IBASIC</td><td>IBASIC Cntrl</td></tr> </table>	Exec	Execution Cond	Cnfg	External Devices	Print	Printer Setup	IBASIC	IBASIC Cntrl
Freq	Channel Information																		
Parm	Test Parameters																		
Seqn	Order of Tests																		
Spec	Pass/Fail Limits																		
Proc	Save/Delete Procedure																		
Exec	Execution Cond																		
Cnfg	External Devices																		
Print	Printer Setup																		
IBASIC	IBASIC Cntrl																		

1	Run Test
2	Continue
4	Help

To Screen

CDMA
CALL CNTL

Analog
RX TEST

Config
TESTS

TESTS (Channel Information)

Entry#	Fwd Loss dB	Rev Loss dB	Test?	Print?	Insert CH
Cell Channel	Options				
1	0.000000	0.000000	Yes/No	Yes/No	Insert CH
	384	END			Delete CH
2	0.000000	0.000000	No	No	Print All
3	0.000000	0.000000	No	No	Help
4	0.000000	0.000000	No	No	Main Menu
5	0.000000	0.000000	No	No	To Screen
6	0.000000	0.000000	No	No	<input checked="" type="radio"/> CDMA
7	0.000000	0.000000	No	No	CALL CNTL
8	0.000000	0.000000	No	No	<input type="radio"/> Analog
					RX TEST
					Config
					TESTS

Chapter 3, Customizing a Test Procedure To Specify Channel Information

3. Select the desired channel information entry number.

- Position the cursor at the **Entry#** field and select it.
- Rotate the knob until the desired **Entry#** field is highlighted and select it.



Entry#	Fwd Loss dB	Rev Loss dB	Test?	Print?
1	0.00000 084	0.00000 END	Yes/No	Yes/No
2	0.00000	0.00000	No	No
3	0.00000	0.00000	No	No
4	0.00000	0.00000	No	No
5	0.00000	0.00000	No	No
6	0.00000	0.00000	No	No
7	0.00000	0.00000	No	No
8	0.00000	0.00000	No	No

TESTS (Channel Information)

Insert CH
Delete CH
Print All
Help
Main Menu

To Screen
CDMA
CALL_CNTL
Analog
RX TEST
Config
TESTS

4. Enter the path loss and channel number.

- Position the cursor at the **Cell Channel** field and select it.
- Use the DATA keys to enter the channel number.
- Press the ENTER key to enter the channel number.
- Position the cursor at the **Fwd** (or **Rev**) **Loss dB** field and select it.
- Use the DATA keys to enter the path loss for the forward or reverse channel frequency.
- Press the ENTER key to enter the path loss value.

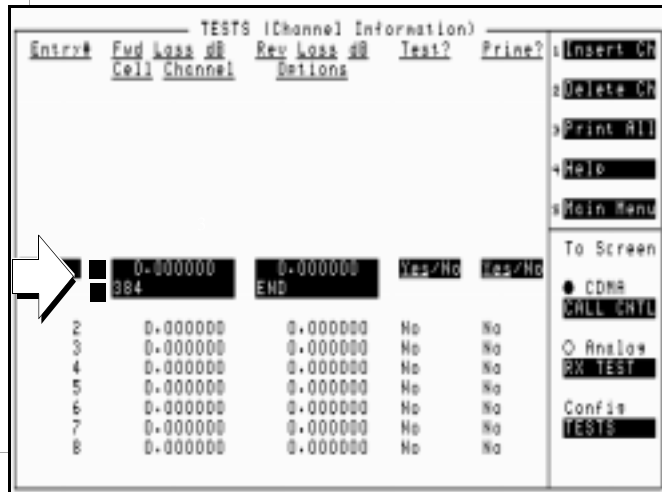

Cell Channel

- For analog AMPS channels enter the voice channel numbers
- For analog narrowband AMPS (NAMPS) channels enter the voice channel number followed by a lower, middle, or upper channel indicator by appending an **L**, **M**, or **U** after the voice channel number. For example: NAMPS voice channel 156 lower would be entered as 156L.
- For CDMA calls in the AMPS (cellular) band, enter the RF channel number.
- For CDMA calls in the US PCS¹ band, enter the RF channel number followed by the letter **P**
- For CDMA calls in the Korean PCS plan 0¹ band, enter the RF channel number followed by the letter **A**
- For CDMA calls in the Korean PCS plan 1¹ band, enter the RF channel number followed by the letter **B**

1. PCS band testing is available only with HP 83217A Option 004 software

5. Select whether to test this channel when the test procedure is run.

- a. Position the cursor at **Test?** field and select **Yes** or **No**.

Entry#	Fwd Loss dB	Rev Loss dB	Test?	Prime?
1	0.000000	0.00	Yes/No	Yes/No
2	0.000000	0.000000	No	No
3	0.000000	0.000000	No	No
4	0.000000	0.000000	No	No
5	0.000000	0.000000	No	No
6	0.000000	0.000000	No	No
7	0.000000	0.000000	No	No
8	0.000000	0.000000	No	No

Test?

- **Yes/No** specifies whether you want to test the UUT at this channel.

If set to **No** then the UUT will not be tested at this channel, but you may retain the channel information in the table for later use.

If set to **Yes** then the channel will be tested as determined by the settings of the **Prime?** field and the **All Chans?** field on the TESTS (Order of Tests) screen.

See "[Interactions Between the Test?, Prime?, and All Chans? Fields](#)" on page 187 for detailed information about how to set this field.

6. Select whether this channel is designated as a prime channel.

a. Position the cursor at **Prime?** field and select Yes or No.

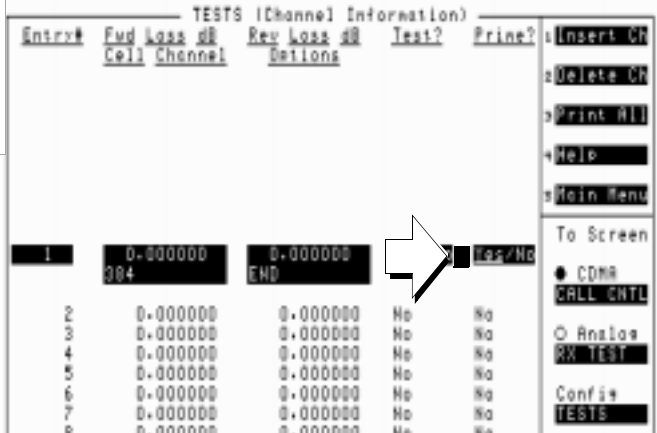

Entry#	Fwd Loss dB	Cell Channel	Rev Loss dB	Test?	Prime?
1	0.00000	304	0.00000	END	Yes/No
2	0.00000		0.00000	No	No
3	0.00000		0.00000	No	No
4	0.00000		0.00000	No	No
5	0.00000		0.00000	No	No
6	0.00000		0.00000	No	No
7	0.00000		0.00000	No	No
8	0.00000		0.00000	No	No

Prime?

- **Yes/No** specifies which channels are “prime.”

If set to **Yes**, the channel is designated as a prime channel and all tests in the test procedure will be run on this channel.

If set to **No**, the channel is designated as a non-prime channel and only tests run on all channels (prime and non-prime) will be run on this channel. This gives you the capability to run a subset of the tests in the test procedure on selected channels. A test is designated to be run on all channels (prime and non-prime) by setting the **All Chans?** field for that test to **Yes** on the TESTS (Order of Tests) screen.

See "[Interactions Between the Test?, Prime?, and All Chans? Fields](#)" on page 187 for detailed information about how to set this field.

Chapter 3, Customizing a Test Procedure To Specify Channel Information

7. Enter END in the Options field.

- a. Position the cursor at the **Options** field of the last channel you wish to have tested when the test procedure is run and select it.
- b. In the **Choices:** menu, select the letters to spell **END**, and then select **Done**.

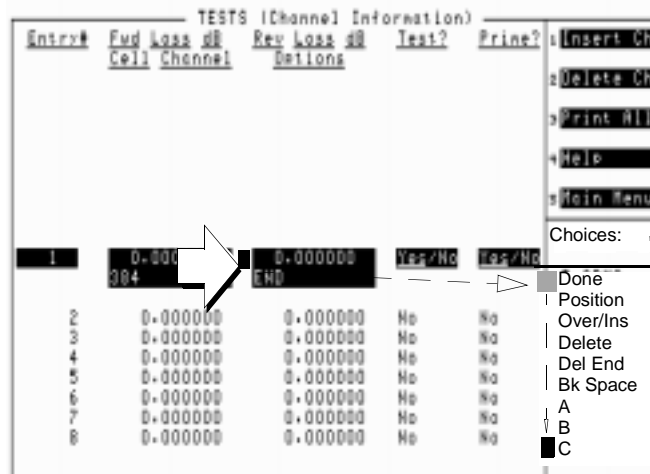

Options

- Entering **END** for the last channel that you want tested will speed up the testing time.

To Change Test Parameters

The software uses parameters to optimize the test environment and conditions for your testing situation. The software comes with default settings for test parameters. Review the defaults and determine if they are adequate for your particular needs.

The [following example](#) shows how to change test parameters to fit your needs.

For information on saving customized test parameters, see "[To Save a Customized Test Procedure](#)" on page 75.

1. Load a test procedure.

- a. If a test procedure is already loaded into the Test Set's memory, go to step 2 .
- b. If a test procedure is not loaded in the Test Set's memory, perform the procedure on "[To Exit and Re-enter a Test Procedure](#)" on page 30, then return to this procedure, step 2.

HP 8924C/E

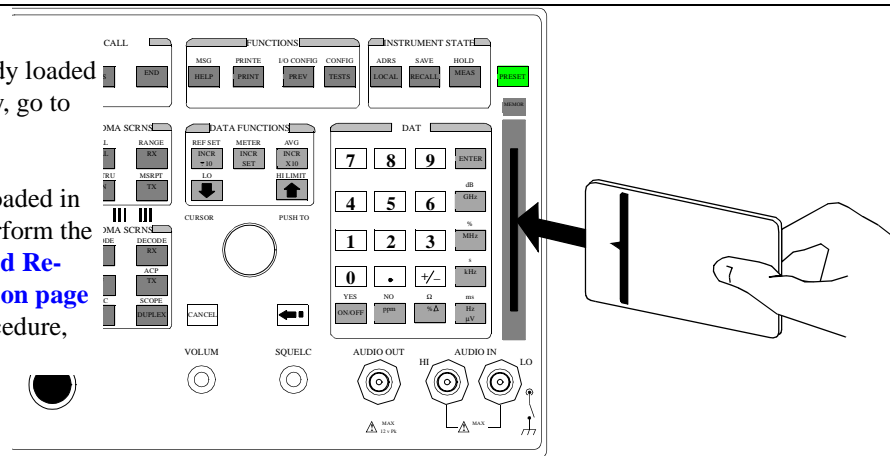

HP E8285A

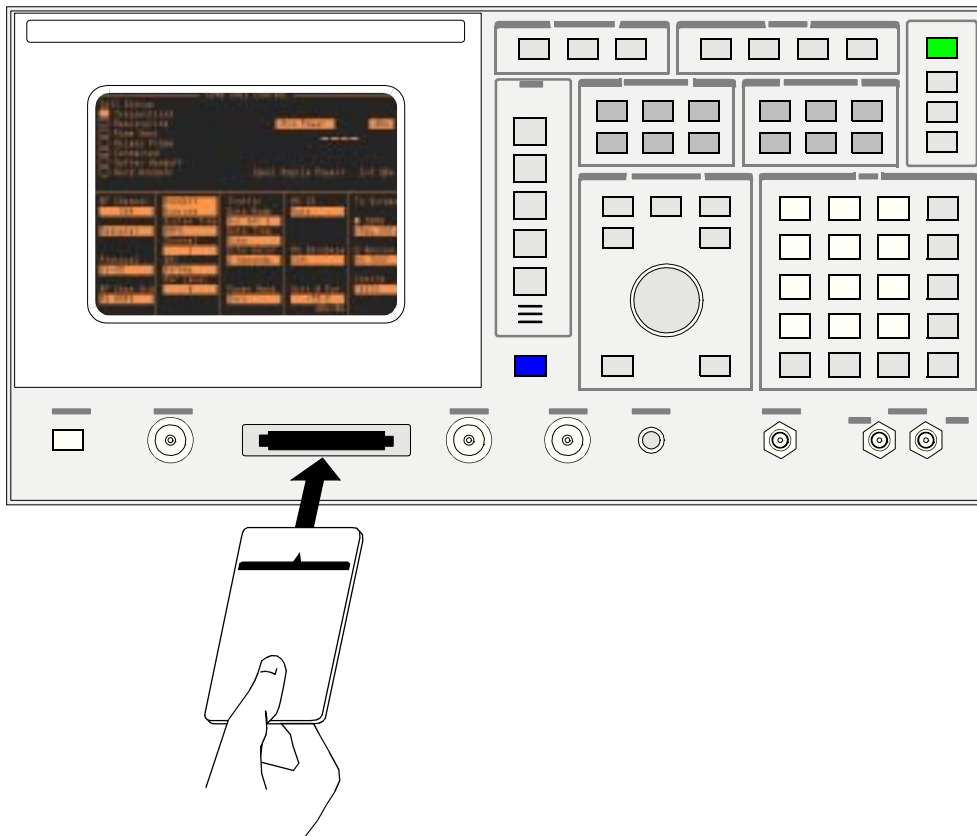

2. Select the screen for changing test environment and conditions.

a. Position the cursor at the **Test Parameters** field and select it.

b. Verify that the TESTS (Test Parameters) screen appears.

TESTS (Main Menu)

P 83217A Software Name

TEST PROCEDURE:
Procedure Location:

Procedure Filename: Library: Program:

Description:

CUSTOMIZE TEST PROCEDURE: SET UP TEST SET:

<table style="width: 100%; border-collapse: collapse;"> <tr> <td style="width: 20px; text-align: right;">Freq</td> <td>Channel Information</td> <td style="width: 20px; text-align: right;">Exec</td> <td>Execution Cond</td> </tr> <tr> <td style="text-align: right;">Parm</td> <td>Test Parameters</td> <td style="text-align: right;">Cnfg</td> <td>External Devices</td> </tr> <tr> <td style="text-align: right;">Seqn</td> <td>Order of Tests</td> <td style="text-align: right;">Print</td> <td>Printer Setup</td> </tr> <tr> <td style="text-align: right;">Spec</td> <td>Pass/Fail Limits</td> <td style="text-align: right;">IBASIC</td> <td>IBASIC Cntrl</td> </tr> <tr> <td style="text-align: right;">Proc</td> <td>Save/Delete Procedure</td> <td></td> <td></td> </tr> </table>	Freq	Channel Information	Exec	Execution Cond	Parm	Test Parameters	Cnfg	External Devices	Seqn	Order of Tests	Print	Printer Setup	Spec	Pass/Fail Limits	IBASIC	IBASIC Cntrl	Proc	Save/Delete Procedure			<p>1 Run Test</p> <p>2 Continue</p> <p>4 Help</p> <hr/> <p>To Screen</p> <p><input type="radio"/> CDMA CALL CNTL</p> <p><input type="radio"/> Analog RX TEST</p> <p><input type="radio"/> Config TESTS</p>
Freq	Channel Information	Exec	Execution Cond																		
Parm	Test Parameters	Cnfg	External Devices																		
Seqn	Order of Tests	Print	Printer Setup																		
Spec	Pass/Fail Limits	IBASIC	IBASIC Cntrl																		
Proc	Save/Delete Procedure																				

TESTS (Test Parameters)

<u>Parm#</u>	<u>Description</u>	<u>Value</u> <u>Units</u>
3	Print All	
4	Help	
5	Main Menu	
<hr/>		
To Screen		
<input type="radio"/> CDMA CALL CNTL		
<input type="radio"/> Analog RX TEST		
<input type="radio"/> Config TESTS		

<u>Parm#</u>	<u>Description</u>	<u>Value</u> <u>Units</u>
1	GN always cal sig/scan [0=no 1=yes]	0.000000
2	GN auto exit adj [0=no xx=times in spec]	
3	GN C-I-T-E Average Voice Level [AVL]	
4	GN C-I-T-E configuration [0=A 1=B 2=C]	
5	GN C-I-T-E has LNA [0=no 1=yes]	
6	GN C-I-T-E setup [1=single 2=2up 3=3up]	
7	GN C-I-T-E VCC number for unit #1	
8	GN C-I-T-E VCC number for unit #2/3	

Chapter 3, Customizing a Test Procedure To Change Test Parameters

3. Select which parameter to change.

a. Position the cursor at the **Parm#** field and select it.

b. Rotate the knob until the desired test parameter is displayed and select it.

TESTS (Test Parameters)		
<u>Parm#</u>	<u>Description</u> <u>Value</u>	<u>Units</u>
1	GN always cal sig/scan [0=no 1=yes] 0.000000	
2	GN auto exit adj [0=no xx=times in spec]	
3	GN C-I-T-E Average Voice Level [AVL]	
4	GN C-I-T-E configuration [0=A 1=B 2=C]	
5	GN C-I-T-E has LNA [0=no 1=yes]	
6	GN C-I-T-E setup [1=single 2=2up 3=3up]	
7	GN C-I-T-E VCC number for unit #1	



4. Enter a value for the test parameter.

<p>a. Position the cursor at the value field and select it.</p> <p>b. Use the DATA keys to enter the new value.</p> <p>c. Press the ENTER key to enter the channel information.</p>	<table border="1"> <thead> <tr> <th colspan="3">TESTS (Test Parameters)</th> </tr> <tr> <th><u>Parm#</u></th> <th><u>Description</u> <u>Value</u></th> <th><u>Units</u></th> </tr> </thead> <tbody> <tr> <td>1</td> <td>GN always cal sig/scan [0=no 1=yes]</td> <td></td> </tr> <tr> <td></td> <td>0.000000</td> <td></td> </tr> <tr> <td>2</td> <td>GN auto exit adj [0=no xx=times in spec]</td> <td></td> </tr> <tr> <td>3</td> <td>GN C-I-T-E Average Voice Level [AVL]</td> <td></td> </tr> <tr> <td>4</td> <td>GN C-I-T-E configuration [0=A 1=B 2=C]</td> <td></td> </tr> <tr> <td>5</td> <td>GN C-I-T-E has LNA [0=no 1=yes]</td> <td></td> </tr> <tr> <td>6</td> <td>GN C-I-T-E setup [1=single 2=2up 3=3up]</td> <td></td> </tr> </tbody> </table>	TESTS (Test Parameters)			<u>Parm#</u>	<u>Description</u> <u>Value</u>	<u>Units</u>	1	GN always cal sig/scan [0=no 1=yes]			0.000000		2	GN auto exit adj [0=no xx=times in spec]		3	GN C-I-T-E Average Voice Level [AVL]		4	GN C-I-T-E configuration [0=A 1=B 2=C]		5	GN C-I-T-E has LNA [0=no 1=yes]		6	GN C-I-T-E setup [1=single 2=2up 3=3up]	
TESTS (Test Parameters)																												
<u>Parm#</u>	<u>Description</u> <u>Value</u>	<u>Units</u>																										
1	GN always cal sig/scan [0=no 1=yes]																											
	0.000000																											
2	GN auto exit adj [0=no xx=times in spec]																											
3	GN C-I-T-E Average Voice Level [AVL]																											
4	GN C-I-T-E configuration [0=A 1=B 2=C]																											
5	GN C-I-T-E has LNA [0=no 1=yes]																											
6	GN C-I-T-E setup [1=single 2=2up 3=3up]																											

To Change the Order of Tests

You can define what tests are performed and the order in which they are performed. You can define the order of tests to include one, some or all of the tests available in the library of tests supplied with the software. Tests are performed in the sequence listed in the TESTS (Order of Tests) screen.

NOTE:

Make TEST_01 - CPA Registration (if making analog tests), or TEST_30 - CPD Registration (if making CDMA tests) the first test in your sequence. These tests register each UUT with the Test Set. Once a UUT has been registered with the Test Set, tests TEST_01 or TEST_30 do not need to be performed again unless the UUT is changed, new test software is loaded, or a **SCRATCH C** command is executed in IBASIC.

The test sequence will remain in the Test Set's battery-backed RAM memory until another test sequence is loaded or the existing sequence is modified. For information on saving a customized test sequence, see "[To Save a Customized Test Procedure](#)" on page 75.

The **All Chans?** field provides the capability to run a subset of tests (those tests with a **Yes** response in **All Chans?** field) on selected channels in the channel information table. For more information, see "[Interactions Between the Test?, Prime?, and All Chans? Fields](#)" on page 187.

The following examples describe how to change the order of tests by:

- "[Inserting a Test Into a Test Procedure](#)" on page 59
- "[Deleting A Test From a Test Procedure](#)" on page 64

Inserting a test into a test procedure.

1. Load a test procedure.

- If a test procedure is already loaded into the Test Set's memory, go to step 2 .
- If a test procedure is not loaded in the Test Set's memory, perform the procedure on **"To Exit and Re-enter a Test Procedure"** on page 30, then return to this procedure, step 2.

HP 8924C/E

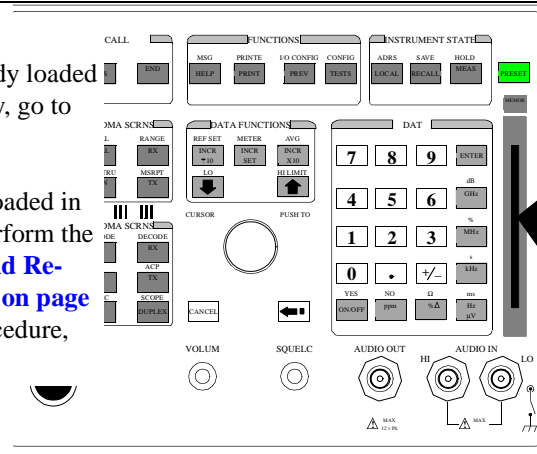

HP E8285A

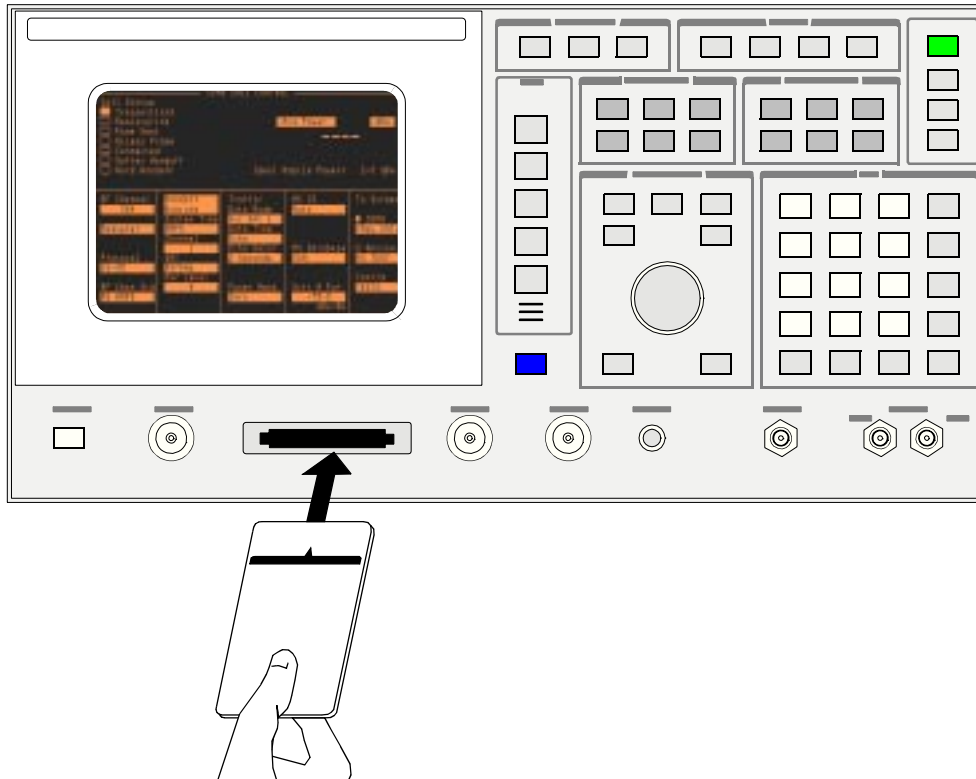

Chapter 3, Customizing a Test Procedure
To Change the Order of Tests

2. Select the screen for inserting a test into a test procedure.

a. Position the cursor at the **Order of Tests** field and select it.

b. Verify that the TESTS (Order of Tests) screen appears.

TESTS (Main Menu)

P 83217A Software Name

TEST PROCEDURE:
 Procedure Location: _____

Procedure Filename: _____ Library: _____ Program: _____

Description: _____

CUSTOMIZE TEST PROCEDURE: SET UP TEST SET:

<table style="width: 100%; border-collapse: collapse;"> <tr><td style="width: 20px;">Freq</td><td>Channel Information</td></tr> <tr><td>Parm</td><td>Test Parameters</td></tr> <tr><td>Seqn</td><td>Order of Tests</td></tr> <tr><td>Spec</td><td>Pass/Fail Limits</td></tr> <tr><td>Proc</td><td>Save/Delete Procedure</td></tr> </table>	Freq	Channel Information	Parm	Test Parameters	Seqn	Order of Tests	Spec	Pass/Fail Limits	Proc	Save/Delete Procedure	<table style="width: 100%; border-collapse: collapse;"> <tr><td style="width: 20px;">Exec</td><td>Execution Cond</td></tr> <tr><td>Cnfg</td><td>External Devices</td></tr> <tr><td>Print</td><td>Printer Setup</td></tr> <tr><td>IBASIC</td><td>IBASIC Cntrl</td></tr> </table>	Exec	Execution Cond	Cnfg	External Devices	Print	Printer Setup	IBASIC	IBASIC Cntrl
Freq	Channel Information																		
Parm	Test Parameters																		
Seqn	Order of Tests																		
Spec	Pass/Fail Limits																		
Proc	Save/Delete Procedure																		
Exec	Execution Cond																		
Cnfg	External Devices																		
Print	Printer Setup																		
IBASIC	IBASIC Cntrl																		

1	Run Test
2	Continue
4	Help

To Screen

CDMA
CALL CNTL

Analog
RX TEST

Config
TESTS

TESTS (Order of Tests)

<u>Step#</u>	<u>Test Name</u> <u>Description</u>	<u>All</u> <u>Chans?</u>		
1			Insrt	Stp
2			Delete	Stp
3			Print	All
4			Help	
5			Main Menu	

To Screen

CDMA
CALL CNTL

Analog
RX TEST

Config
TESTS

3. Select the insertion point for the test that will be inserted into the test procedure.

a. Position the cursor at the **Step#** field and select it.

b. Rotate the knob until the desired insertion point for the new test is highlighted and select it.

c. Position the cursor at **Insrt Stp** field and select it. A copy of the test at the currently selected **Step#** is inserted into the test list and the test list is automatically re-ordered (step 5 becomes step 6, step 6 becomes step 7, and so forth).

The screenshot shows a software interface for editing test procedures. At the top, a title bar reads "TESTS (Order of Tests)". Below this is a table with two columns: "Step#" and "Test Name Description". The first row of the table has a highlighted "Step#" cell containing the number "5" and a corresponding "Test Name Description" cell. To the right of the table is a vertical menu with five numbered options: "1 Insrt S", "2 Delet S", "3 Print A", "4 Help", and "5 Main Mer". Below the menu are several radio button options: "To Scree", "○ CDMA", "CALL CN", "○ Analog", and "RX TEST". A "Yes/No" button is also visible. A mouse cursor is positioned over the "5" in the "Step#" column, and another mouse cursor is pointing at the "1 Insrt S" menu item.

Step#	Test Name Description
5	[Redacted]
[Redacted]	[Redacted]
[Redacted]	[Redacted]
[Redacted]	[Redacted]
[Redacted]	[Redacted]

Chapter 3, Customizing a Test Procedure
To Change the Order of Tests

4. Select the test to be inserted into the test procedure.

a. Position the cursor back to the **Test Name** field of the currently selected **Step#** and select it.

b. From the list of tests in the **Choices:** menu, position the cursor at the desired test number and select it. The selected test name and description are placed in the test list.

The screenshot shows a software interface for editing test procedures. At the top, a table titled "TESTS (Order of Tests)" has columns for "name" and "description". Below this is a "Choices:" menu listing tests from TEST_01 to TEST_08, with TEST_04 selected. To the left, a "Test Description" field contains "TEST_##" and is highlighted by a large arrow. A "Yes/No" button is also visible. On the right side, a vertical menu contains options: 1 Insr Stp, 2 Delet Stp, 3 Print All, 4 Help, 5 Main Menu.

5. Select which channels to run the new test on.

a. Position the cursor on the **All Chans?** field and select **Yes** or **No**.

The screenshot shows a software interface for configuring tests. At the top, a title bar reads "TESTS (Order of Tests)". Below this is a table with three columns: "Step#", "Test Name Description", and "All Chans?". The table contains several rows of test entries, each with a small square icon in the "Step#" column. To the right of the table is a control panel with a vertical list of buttons: "1 Instrt Stp", "2 Delet Stp", "3 Print All", "4 Help", and "5 Main Menu". Below these buttons is a section titled "To Screen" containing three radio button options: "CDMA CALL CNTL", "Analog RX TEST", and "Config TESTS". A white arrow points to a "Yes/No" field located to the right of the table, which is currently set to "No".

All Chans?

- **Yes/No** specifies whether all channels will be tested.
If set to **Yes**, the test procedure will be run on all channels.
If set to **No**, the test will be run on prime channels only.

See "[Interactions Between the Test?, Prime?, and All Chans? Fields](#)" on page 187 for detailed information about how to set this field.

Deleting a test from a test procedure.

1. Load a test procedure.

- a. If a test procedure is already loaded into the Test Set's memory, go to step 2 .
- b. If a test procedure is not loaded in the Test Set's memory, perform the procedure on **"To Exit and Re-enter a Test Procedure"** on page 30, then return to this procedure, step 2.

HP 8924C/E

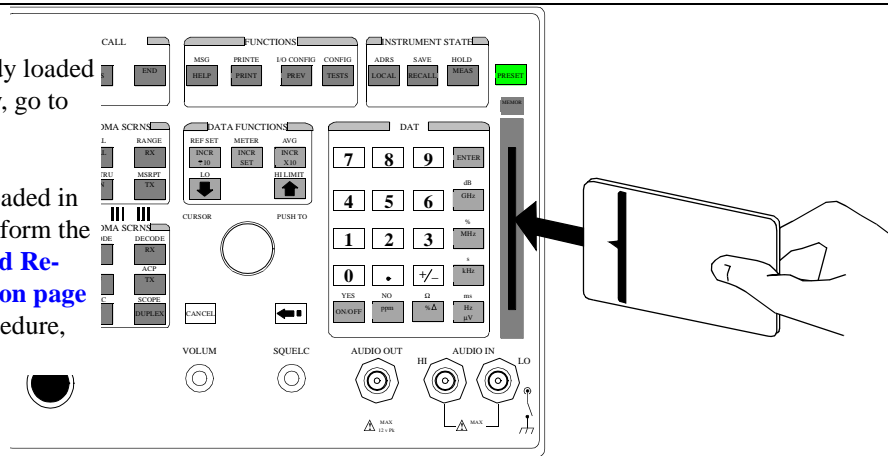

HP E8285A

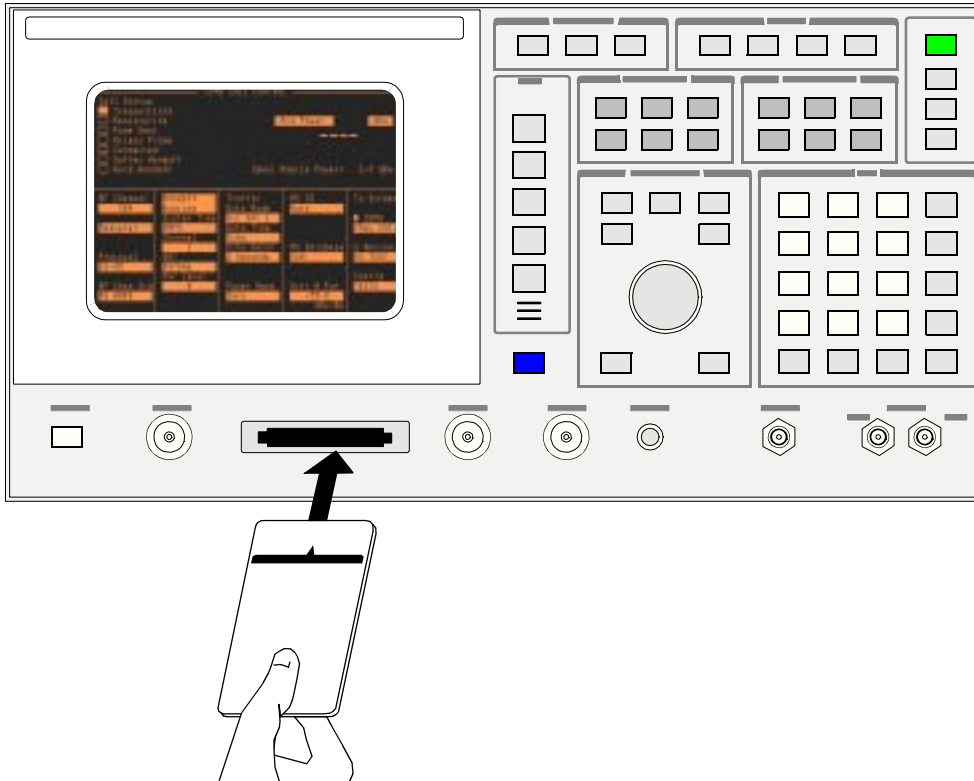

2. Select the screen for deleting a test from a test procedure.

a. Position the cursor at the **Order of Tests** field and select it.

b. Verify that the TESTS (Order of Tests) screen appears.

TESTS (Main Menu)

P 83217A Software Name

TEST PROCEDURE:
Procedure Location:

Procedure Filename: Library: Program:

Description:

CUSTOMIZE TEST PROCEDURE: SET UP TEST SET:

<table style="width: 100%; border-collapse: collapse;"> <tr><td style="width: 20px;">Freq</td><td>Channel Information</td></tr> <tr><td>Parm</td><td>Test Parameters</td></tr> <tr><td>Seqn</td><td>Order of Tests</td></tr> <tr><td>Spec</td><td>Pass/Fail Limits</td></tr> <tr><td>Proc</td><td>Save/Delete Procedure</td></tr> </table>	Freq	Channel Information	Parm	Test Parameters	Seqn	Order of Tests	Spec	Pass/Fail Limits	Proc	Save/Delete Procedure	<table style="width: 100%; border-collapse: collapse;"> <tr><td style="width: 20px;">Exec</td><td>Execution Cond</td></tr> <tr><td>Cnfg</td><td>External Devices</td></tr> <tr><td>Print</td><td>Printer Setup</td></tr> <tr><td>IBASIC</td><td>IBASIC Cntrl</td></tr> </table>	Exec	Execution Cond	Cnfg	External Devices	Print	Printer Setup	IBASIC	IBASIC Cntrl
Freq	Channel Information																		
Parm	Test Parameters																		
Seqn	Order of Tests																		
Spec	Pass/Fail Limits																		
Proc	Save/Delete Procedure																		
Exec	Execution Cond																		
Cnfg	External Devices																		
Print	Printer Setup																		
IBASIC	IBASIC Cntrl																		

1	Run Test
2	Continue
4	Help

To Screen

CDMA
CALL CNTL

Analog
RX TEST

Config
TESTS

TESTS (Order of Tests)

<u>Step#</u>	<u>Test Name</u> <u>Description</u>	<u>All</u> <u>Chans?</u>		
1			Insrt	Stp
2			Delete	Stp
3			Print	All
4			Help	
5			Main Menu	

Yes/No

To Screen

CDMA
CALL CNTL

Analog
RX TEST

Config
TESTS

Chapter 3, Customizing a Test Procedure
To Change the Order of Tests

3. Select the test to be deleted from the test procedure sequence.

a. Position the cursor at the **Step#** field and select it.

b. Rotate the knob until the step number of the test to be deleted is highlighted in the **Step#** field and select it.

TESTS (Order of Tests)			
<u>Step#</u>	<u>Test Name</u> <u>Description</u>	<u>All</u> <u>Chans?</u>	<u>Yes/No</u>
1	[Redacted]		
2	[Redacted]		
3	[Redacted]		
4	[Redacted]		
5	[Redacted]		

1 Instrt Stp
2 Delet Stp
3 Print All
4 Help
5 Main Menu

To Screen
 CDMA
CALL CNTL
 Analog

4. Delete the test from the test procedure sequence.

- a. Position the cursor at the **Delet Stp** field and select it.
- b. The test at the currently selected **Step#** is deleted from the test list and the list is automatically re-ordered (step 05 becomes step 04, step 06 becomes step 05, and so forth).

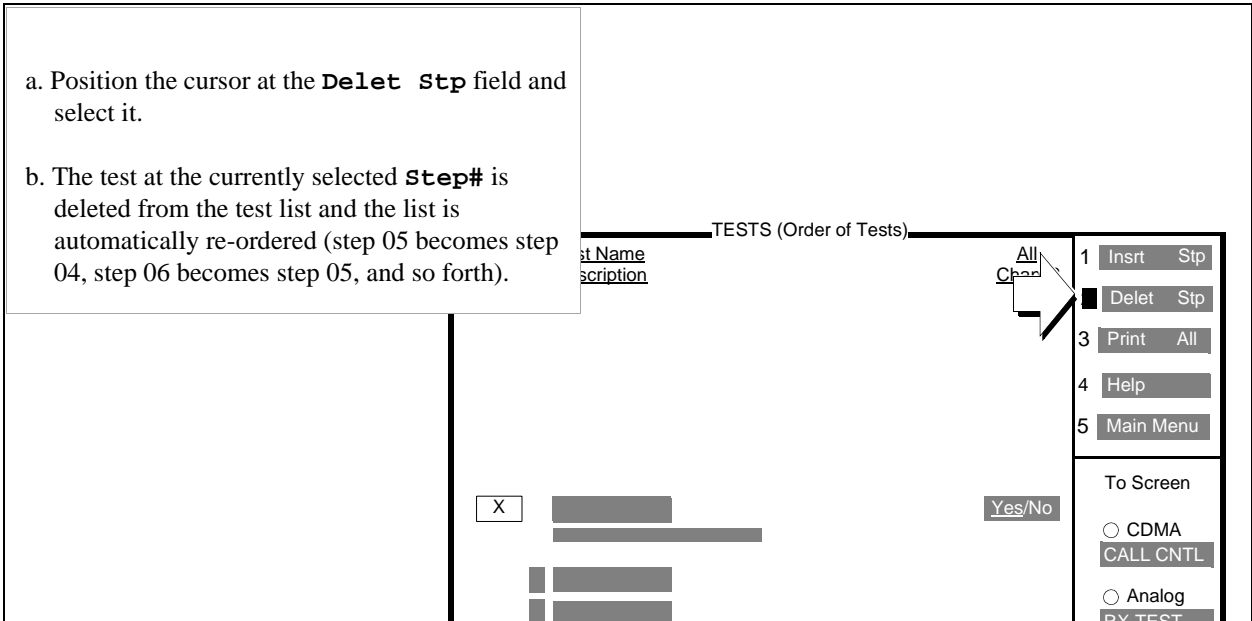

To Change Pass/Fail Limits

Pass/Fail limits, also called specifications, define the values a measurement result is compared against to determine if the UUT meets its specified performance. Default values are set in the software package. Most of these default values may be changed to suit your particular requirements. Some values may be hard-coded into the software. See the software's *Reference Guide* for more information about Pass/Fail Limits.

The [following example](#) describes how to change the pass/fail (upper and lower) limits. For information on saving customized pass/fail limits, see "[To Save a Customized Test Procedure](#)" on page 75.

1. Load a test procedure.

- a. If a test procedure is already loaded, go to step 2 .
- b. If a test procedure is not loaded in the Test Set's memory, perform the procedure on **"To Exit and Re-enter a Test Procedure"** on page 30, then return to this procedure, step 2.

HP 8924C/E

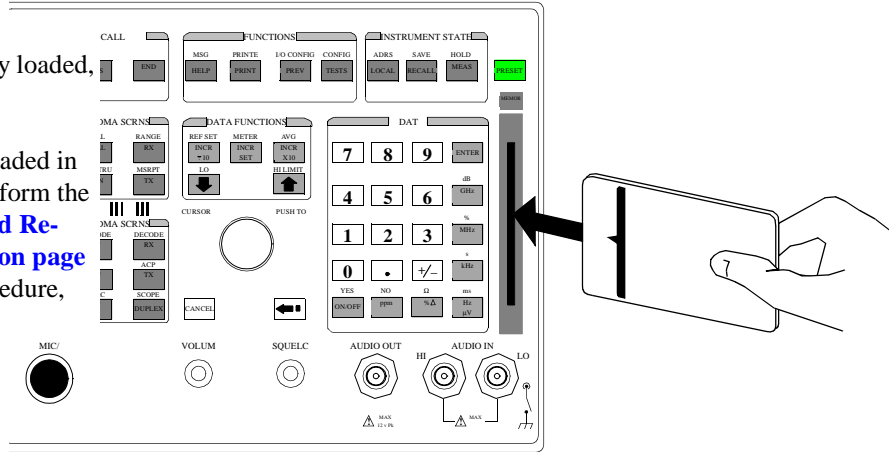

HP E8285A

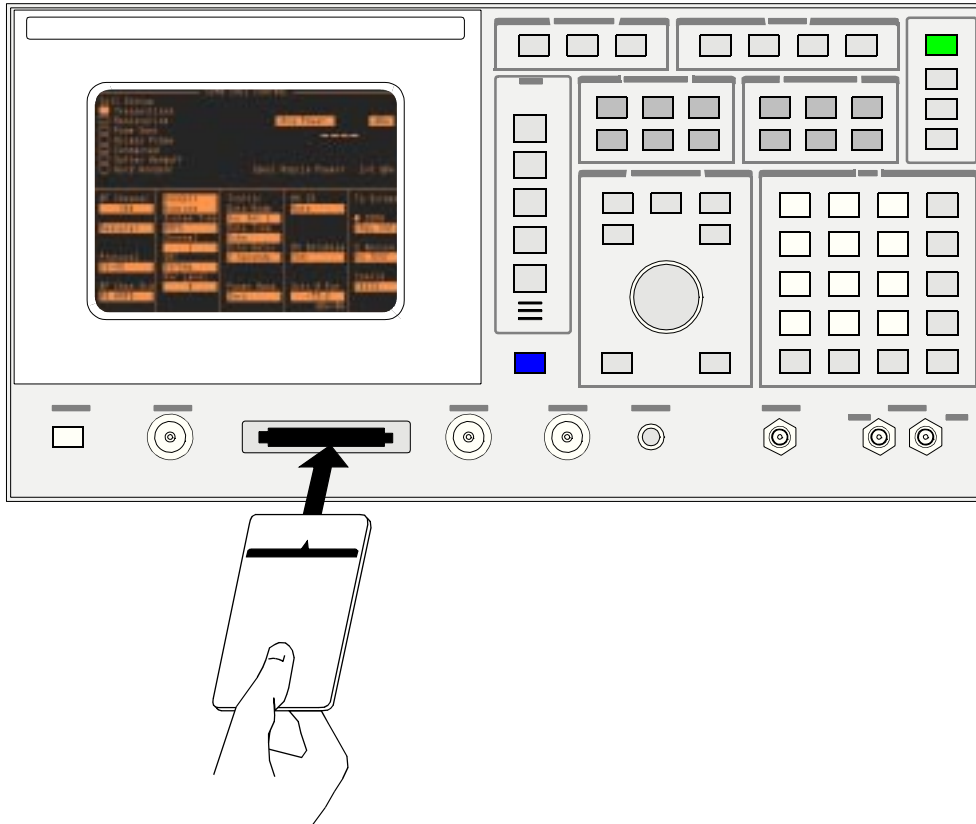

Chapter 3, Customizing a Test Procedure
To Change Pass/Fail Limits

2. Select the screen for changing pass/fail limits.

a. Position the cursor at the **Pass/Fail Limits** field and select it.

b. Verify that the TESTS (Pass/Fail Limits) screen appears.

TESTS (Main Menu)

P 83217A Software Name

TEST PROCEDURE:
 Procedure Location:
 Procedure Filename: Library: Program:

Description:

CUSTOMIZE TEST PROCEDURE: SET UP TEST SET:

<table style="width: 100%; border-collapse: collapse;"> <tr><td style="border: 1px solid black; padding: 2px;">Freq</td><td>Channel Information</td></tr> <tr><td style="border: 1px solid black; padding: 2px;">Parm</td><td>Test Parameters</td></tr> <tr><td style="border: 1px solid black; padding: 2px;">Seqn</td><td>Order of Tests</td></tr> <tr><td style="border: 1px solid black; padding: 2px;">Spec</td><td>Pass/Fail Limits</td></tr> <tr><td style="border: 1px solid black; padding: 2px;">Proc</td><td>Save/Delete Procedure</td></tr> </table>	Freq	Channel Information	Parm	Test Parameters	Seqn	Order of Tests	Spec	Pass/Fail Limits	Proc	Save/Delete Procedure	<table style="width: 100%; border-collapse: collapse;"> <tr><td style="border: 1px solid black; padding: 2px;">Exec</td><td>Execution Cond</td></tr> <tr><td style="border: 1px solid black; padding: 2px;">Cnfg</td><td>External Devices</td></tr> <tr><td style="border: 1px solid black; padding: 2px;">Print</td><td>Printer Setup</td></tr> <tr><td style="border: 1px solid black; padding: 2px;">IBASIC</td><td>IBASIC Cntrl</td></tr> </table>	Exec	Execution Cond	Cnfg	External Devices	Print	Printer Setup	IBASIC	IBASIC Cntrl
Freq	Channel Information																		
Parm	Test Parameters																		
Seqn	Order of Tests																		
Spec	Pass/Fail Limits																		
Proc	Save/Delete Procedure																		
Exec	Execution Cond																		
Cnfg	External Devices																		
Print	Printer Setup																		
IBASIC	IBASIC Cntrl																		

1 Run Test

2 Continue

4 Help

To Screen

CDMA
CALL CNTL

Analog
RX TEST

Config
TESTS

TESTS (Pass/Fail Limits)

Spec#	Description	Lower Limit	Upper Limit	Units	Check
<p>3 Print All</p> <p>4 Help</p> <p>5 Main Menu</p>	<p>1 RXA Audio Distortion</p> <p>2 RXA Audio Output Level</p> <p>3 RXA Audio Response Dev from -6 dB/oct R1</p> <p>4 RXA Audio Response Dev from -6 dB/oct R2</p> <p>5 RXA Expander Track Error <0 dB</p> <p>6 RXA Expander Track Error >0 dB</p> <p>7 RXA Hum and Noise</p> <p>8 RXA Scan and Sig Calibration Reading</p>	<p>0.000000</p> <p>5.000000</p>	%	Upper	<p>To Screen</p> <p><input type="radio"/> CDMA CALL CNTL</p> <p><input type="radio"/> Analog RX TEST</p> <p><input type="radio"/> Config TESTS</p>

70

S:\HP83217A\USRGUIDE\BOOK\Chapters\3custom.fb

3. Select which pass/fail limits to change.

a. Position the cursor at the **Spec#** field and select it.

b. Rotate the knob until the desired specification is displayed and select it.

Spec#	Description	Lower Limit	Upper Limit	Units	Check
1	RXA Audio Distortion	0.000000	5.000000	%	Upper
2	RXA Audio Output Level				
3	RXA Audio Response Dev from -6 dB/oct R1				
4	RXA Audio Response Dev from -6 dB/oct R2				
5	RXA Expander Track Error <0 dB				

3 Print

4 Help

5 Main Me

To Screenshot

CDM/

CALL C

Analo

RX TES

4. Enter a new lower limit for the specification.

a. Position the cursor at the **Lower Limit** field and select it.

b. Use the DATA keys to enter the new value.

c. Press the ENTER key to terminate the entry.

TESTS (Pass/Fail Limits)				
#	Description	Lower Limit	Upper Limit	Units
1	RXA Audio Distortion	0.000000	5.000000	%
2	RXA Audio Output Level			
3	RXA Audio Response Dev from -6 dB/oct R1			
4	RXA Audio Response Dev from -6 dB/oct R2			
5	RXA Expander Track Error <0 dB			

Upper

3 Print

4 Help

5 Main Men

To Screen

CDMA
CALL CN

Analog
RX TEST

5. Enter a new upper limit for the specification.

- a. Position the cursor at the **Upper Limit** field and select it.
- b. Use the DATA keys to enter the new value.
- c. Press the ENTER key to terminate the entry.

TESTS (Pass/Fail Limits)					
#	Description	Lower Limit	Upper Limit	Units	Check
1	RXA Audio Distortion	0.0	5.000000	%	Upper
2	RXA Audio Output Level				
3	RXA Audio Response Dev from -6 dB/oct R1				
4	RXA Audio Response Dev from -6 dB/oct R2				
5	RXA Expander Track Error <0 dB				

3 Print

4 Help

5 Main Men

To Screen

CDMA

CALL CN

Analog

RX TEST

6. Select how the pass/fail limits should be applied to the measurement result.

a. Position the cursor at the **Check** field and select it.

b. Select the desired mode from the **Choices:** menu.

	TESTS (Pass/Fail Limits)		
	Upper Limit	Units	Check
1	RXA Audio Distortion 0.000000 5.000000	%	Upper
2	RXA Audio Output Level		
3	RXA Audio Response Dev from -6 dB/oct R1		
4	RXA Audio Response Dev from -6 dB/oct R2		
5	RXA Expander Track Error <0 dB		
6	RXA Expander Track Error >0 dB		

3 Print All

4 Help

5 Main Menu

Choices:

- Upper
- Lower
- Both
- None

Check

- Upper = check measurement result against upper limit only
- Lower = check measurement result against lower limit only
- Both = check measurement result against upper & lower limits
- None = do not check measurement result against limits

To Save a Customized Test Procedure

This example procedure is provided to show how to save a customized test procedure.

A test procedure is a file customizes the test software to a specific application. A test procedure file contains the following information:

- channel information
- test parameters
- pass/fail limits
- a testing order (sequence)

You may save the file to a memory card or disk. When you save a procedure you will be saving the information listed above, plus the software's library file. See ["library" on page 208](#) for a definition of a library file.

For information about deleting a test procedure from a mass storage device, see ["Deleting A Test Procedure" on page 84](#).

The [following example](#) describes how to save a customized test procedure to a memory card. The example describes the steps to take when you have loaded an existing test procedure into the Test Set, modified it for your application, and now wish to save it as a new test procedure.

1. Load an initialized SRAM memory card.

Ensure that a test procedure has been loaded into the Test Set and has been modified. See ["To Load a Test Procedure" on page 16](#) for instructions for loading a test procedure.

See ["To Initialize a Memory Card \(DOS Format\)" on page 167](#), or see ["To Initialize a Memory Card \(LIF Format\)" on page 172](#) for information on how to initialize a memory card.

2. Select the screen for saving a customized test procedure.

a. Position the cursor at the **Save/Delete Procedure** field and select it.

b. Verify that the TESTS (Save/Delete Procedure) screen appears.

TESTS (Main Menu)

P 83217A Software Name

TEST PROCEDURE:
Procedure Location:

Procedure Filename: Library: Program:

Description:

CUSTOMIZE TEST PROCEDURE: SET UP TEST SET:

<table style="width: 100%; border-collapse: collapse;"> <tr><td style="width: 20px;">Freq</td><td>Channel Information</td></tr> <tr><td>Parm</td><td>Test Parameters</td></tr> <tr><td>Seqn</td><td>Order of Tests</td></tr> <tr><td>Spec</td><td>Pass/Fail Limits</td></tr> <tr><td>Proc</td><td>Save/Delete Procedure</td></tr> </table>	Freq	Channel Information	Parm	Test Parameters	Seqn	Order of Tests	Spec	Pass/Fail Limits	Proc	Save/Delete Procedure	<table style="width: 100%; border-collapse: collapse;"> <tr><td style="width: 20px;">Exec</td><td>Execution Cond</td></tr> <tr><td>Cnfg</td><td>External Devices</td></tr> <tr><td>Print</td><td>Printer Setup</td></tr> <tr><td>IBASIC</td><td>IBASIC Cntrl</td></tr> </table>	Exec	Execution Cond	Cnfg	External Devices	Print	Printer Setup	IBASIC	IBASIC Cntrl
Freq	Channel Information																		
Parm	Test Parameters																		
Seqn	Order of Tests																		
Spec	Pass/Fail Limits																		
Proc	Save/Delete Procedure																		
Exec	Execution Cond																		
Cnfg	External Devices																		
Print	Printer Setup																		
IBASIC	IBASIC Cntrl																		

1 Run Test

2 Continue

4 Help

To Screen

CDMA
CALL CNTL

Analog
RX TEST

Config
TESTS

TESTS (Save/Delete Procedures)

SAVE/DELETE TEST PROCEDURE:

Select Procedure Location:
Card

Enter Procedure Filename:

Enter Description for New Procedure:

SAVE PROCEDURE INFORMATION:

Procedure Library:
Current/[No Lib]

Code Location:
Card

Password

1 Save Proc

2 Del Proc

3 Init Card

4 Help

5 Main Menu

To Screen

CDMA
CALL CNTL

Analog
RX TEST

Config
TESTS

Chapter 3, Customizing a Test Procedure To Save a Customized Test Procedure

3. Select where to save the customized test procedure.

a. Position the cursor at the **Select Procedure Location:** field and select it.

b. Select the desired medium from the **Choices:** menu. In this example **Card** is selected.

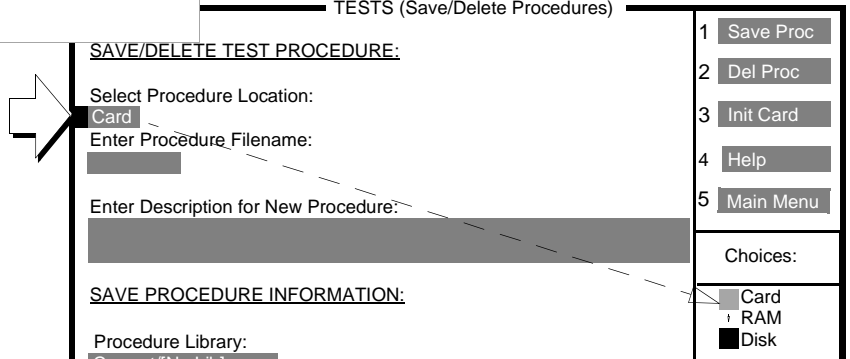

The screenshot shows the 'TESTS (Save/Delete Procedures)' menu. The 'SAVE/DELETE TEST PROCEDURE:' section includes fields for 'Select Procedure Location:' (with 'Card' selected), 'Enter Procedure Filename:', and 'Enter Description for New Procedure:'. The 'SAVE PROCEDURE INFORMATION:' section includes 'Procedure Library:' (with 'Current/[No Lib]' selected). The 'Choices:' menu is open, showing 'Card' selected, 'RAM', and 'Disk'. A dashed line connects the 'Card' selection in the 'Choices' menu to the 'Card' selection in the 'Select Procedure Location:' field.

1	Save Proc
2	Del Proc
3	Init Card
4	Help
5	Main Menu

Choices:

- Card
- RAM
- Disk

4. Enter a name for the new customized test procedure.

- a. Position the cursor at the **Enter Procedure Filename:** field and select it.
- b. Select the letters to spell the name of the procedure from the **Choices:** menu, then select **Done**.

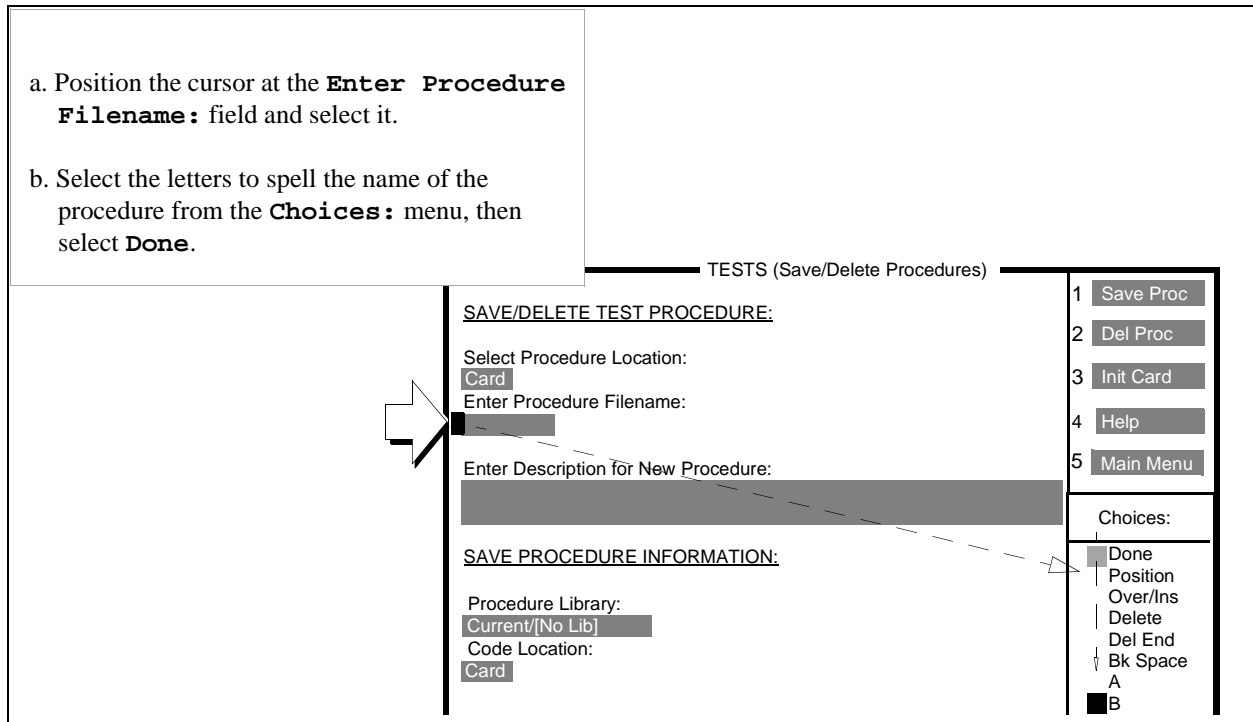

5. Enter a description of the customized test procedure.

a. Position the cursor at the Enter Description for New Procedure field and select it.

b. Select the letters to spell the description of the procedure from the **Choices:** menu, then select **Done**.

The screenshot shows a terminal window titled "TESTS (Save/Delete Procedures)". The main menu has five numbered options: 1 Save Proc, 2 Del Proc, 3 Init Card, 4 Help, and 5 Main Menu. A sub-menu titled "Choices:" is open, showing options: Done, Position, Over/Ins, Delete, Del End, Bk Space, A, B, and C. The "Done" option is highlighted with a grey bar. In the background, the "Enter Description for New Procedure:" field is highlighted with a grey bar, and a white arrow points to it from the left. Below this field is the "SAVE PROCEDURE INFORMATION:" section, which includes fields for "Procedure Library:" (Current/[No Lib]), "Code Location:" (Card), and "Password".

Enter Description for New Procedure:

You can use this field to enter a description, of up to 100 characters.

The **Enter Description for New Procedure:** field consists of two independent 50 character fields. Position the cursor on the upper field to enter up to 50 characters. Position the cursor on the lower field to enter up to 50 characters. You must select **Done** after each line is filled.

6. Select whether you want use the software's library file for the customized test procedure.

a. Position the cursor at the **Procedure Library:** field and select **Current**.

TESTS (Save/Delete Procedures)

TEST PROCEDURE:

Select Procedure Location:
Card

Enter Procedure Filename:
[REDACTED]

Enter Description for New Procedure:
[REDACTED]

SAVE PROCEDURE INFORMATION:

Procedure Library:
Current/[No Lib]

Code Location:
Card

1 Save Proc
2 Del Proc
3 Init Card
4 Help
5 Main Menu

To Screen
 CDMA
CALL CNTL
 Analog
RX TEST

7. Select the mass storage location where the customized test procedure will look for its code file when the test procedure is run.

a. Position the cursor at the **Code Location:** field and select it.

b. Position the cursor at the desired medium in the **Choices:** menu and select it. This example uses **Card**.

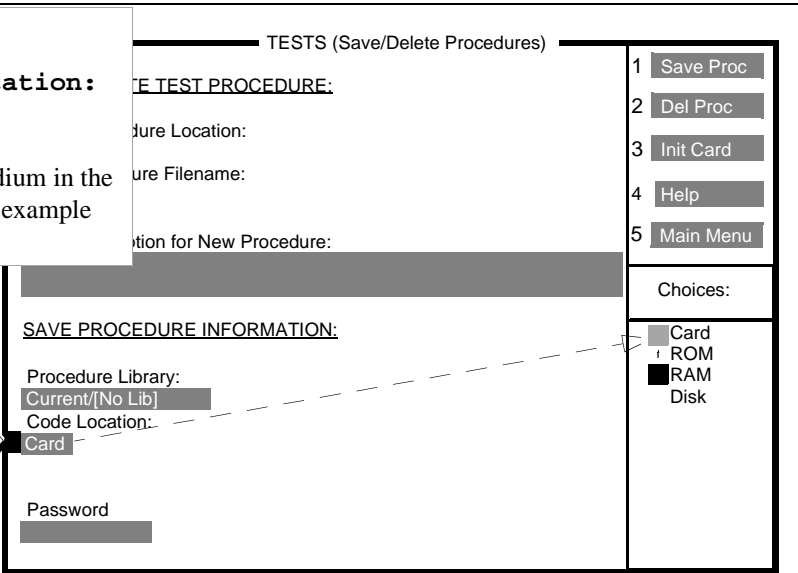

The screenshot shows a terminal window titled "TESTS (Save/Delete Procedures)". The main area contains the following text:
TEST PROCEDURE:
Procedure Location:
Procedure Filename:
Location for New Procedure:

SAVE PROCEDURE INFORMATION:
Procedure Library:
Current/[No Lib]
Code Location:
Card

Password

On the right side, there is a vertical menu with five options: 1 Save Proc, 2 Del Proc, 3 Init Card, 4 Help, and 5 Main Menu. Below this menu is a "Choices:" section with three radio button options: Card, ROM, and Disk. The "Card" option is selected, indicated by a solid black square next to it. A dashed arrow points from the "Code Location:" field in the main area to the "Card" option in the "Choices:" menu. A solid arrow points from the left margin to the "Code Location:" field.

8. Save the test procedure.

a. Position the cursor at the **Save Proc** field and select it, or press USER key K1.

TESTS (Save/Delete Procedures)

1 Save Proc

2 Del Proc

3 Init Card

4 Help

5 Main Menu

Choices:

CDMA
CALL CNTL

Analog
RX TEST

Config
TESTS

Procedure Location:

Procedure Filename:

Enter Description for New Procedure:

SAVE PROCEDURE INFORMATION:

Procedure Library:
Current/[No Lib]

Code Location:
Card

Password

IMPORTANT

To run any test procedure, the Test Set must have access to the software's code file in its memory, or the software card must be in the memory card slot.

To ensure that the software's code file is accessible, reinstall the software card after recalling your test procedure.

Deleting A Test Procedure

Test procedures can be removed from an SRAM memory card, external disk or RAM disk. The [following example](#) shows how to delete a procedure.

1. Activate the Tests Subsystem.

a. Press the TESTS key.

HP 8924C/E

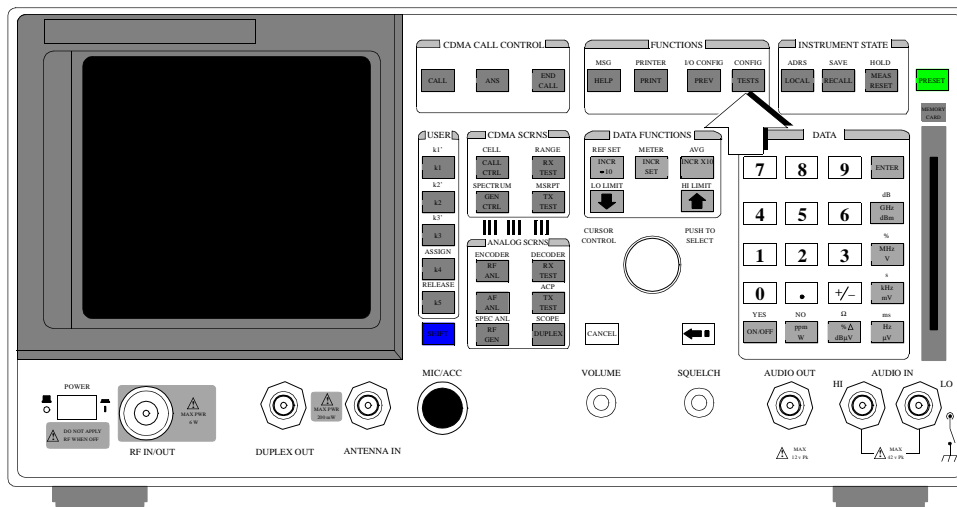

HP E8285A

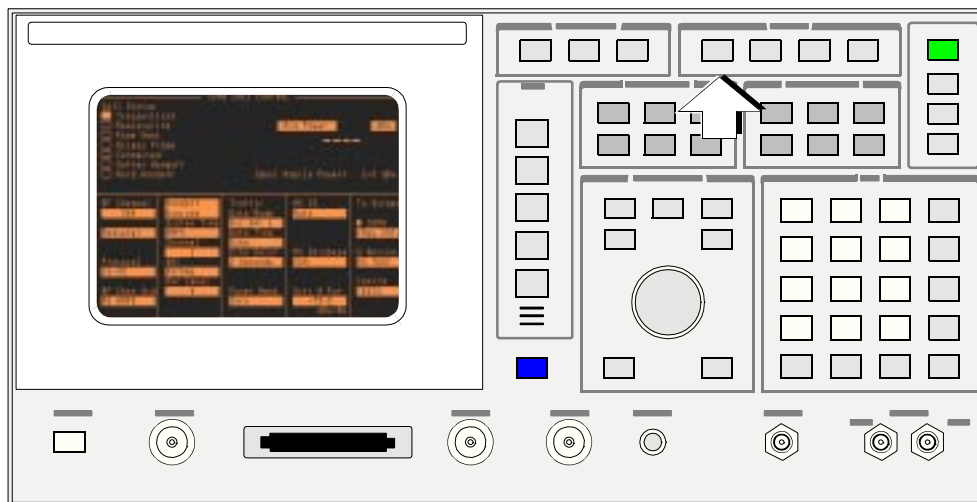

Chapter 3, Customizing a Test Procedure
 Deleting A Test Procedure

2. Select the screen for deleting a test procedure.

a. Position the cursor at the **Save/Delete Procedure** field and select it.

b. Verify that the TESTS (Save/Delete Procedure) screen appears.

TESTS (Main Menu)

P 83217A Software Name

TEST PROCEDURE:
 Procedure Location:

Procedure Filename: Library: Program:

Description:

CUSTOMIZE TEST PROCEDURE: SET UP TEST SET:

<table style="width: 100%; border-collapse: collapse;"> <tr> <td style="width: 50%; border-right: 1px solid black; padding-right: 5px;"> <table style="width: 100%; border-collapse: collapse;"> <tr><td style="border: 1px solid black; padding: 2px;">Freq</td><td>Channel Information</td></tr> <tr><td style="border: 1px solid black; padding: 2px;">Parm</td><td>Test Parameters</td></tr> <tr><td style="border: 1px solid black; padding: 2px;">Seqn</td><td>Order of Tests</td></tr> <tr><td style="border: 1px solid black; padding: 2px;">Spec</td><td>Pass/Fail Limits</td></tr> <tr><td style="border: 1px solid black; padding: 2px;">Proc</td><td>Save/Delete Procedure</td></tr> </table> </td> <td style="width: 50%; padding-left: 5px;"> <table style="width: 100%; border-collapse: collapse;"> <tr><td style="border: 1px solid black; padding: 2px;">Exec</td><td>Execution Cond</td></tr> <tr><td style="border: 1px solid black; padding: 2px;">Cnfg</td><td>External Devices</td></tr> <tr><td style="border: 1px solid black; padding: 2px;">Print</td><td>Printer Setup</td></tr> <tr><td style="border: 1px solid black; padding: 2px;">IBASIC</td><td>IBASIC Cntrl</td></tr> </table> </td> </tr> </table>	<table style="width: 100%; border-collapse: collapse;"> <tr><td style="border: 1px solid black; padding: 2px;">Freq</td><td>Channel Information</td></tr> <tr><td style="border: 1px solid black; padding: 2px;">Parm</td><td>Test Parameters</td></tr> <tr><td style="border: 1px solid black; padding: 2px;">Seqn</td><td>Order of Tests</td></tr> <tr><td style="border: 1px solid black; padding: 2px;">Spec</td><td>Pass/Fail Limits</td></tr> <tr><td style="border: 1px solid black; padding: 2px;">Proc</td><td>Save/Delete Procedure</td></tr> </table>	Freq	Channel Information	Parm	Test Parameters	Seqn	Order of Tests	Spec	Pass/Fail Limits	Proc	Save/Delete Procedure	<table style="width: 100%; border-collapse: collapse;"> <tr><td style="border: 1px solid black; padding: 2px;">Exec</td><td>Execution Cond</td></tr> <tr><td style="border: 1px solid black; padding: 2px;">Cnfg</td><td>External Devices</td></tr> <tr><td style="border: 1px solid black; padding: 2px;">Print</td><td>Printer Setup</td></tr> <tr><td style="border: 1px solid black; padding: 2px;">IBASIC</td><td>IBASIC Cntrl</td></tr> </table>	Exec	Execution Cond	Cnfg	External Devices	Print	Printer Setup	IBASIC	IBASIC Cntrl	<p>1 <input type="button" value="Run Test"/></p> <p>2 <input type="button" value="Continue"/></p> <p>4 <input type="button" value="Help"/></p> <hr/> <p>To Screen</p> <p><input type="radio"/> CDMA <input checked="" type="button" value="CALL CNTL"/></p> <p><input type="radio"/> Analog <input checked="" type="button" value="RX TEST"/></p> <p><input type="radio"/> Config <input checked="" type="button" value="TESTS"/></p>
<table style="width: 100%; border-collapse: collapse;"> <tr><td style="border: 1px solid black; padding: 2px;">Freq</td><td>Channel Information</td></tr> <tr><td style="border: 1px solid black; padding: 2px;">Parm</td><td>Test Parameters</td></tr> <tr><td style="border: 1px solid black; padding: 2px;">Seqn</td><td>Order of Tests</td></tr> <tr><td style="border: 1px solid black; padding: 2px;">Spec</td><td>Pass/Fail Limits</td></tr> <tr><td style="border: 1px solid black; padding: 2px;">Proc</td><td>Save/Delete Procedure</td></tr> </table>	Freq	Channel Information	Parm	Test Parameters	Seqn	Order of Tests	Spec	Pass/Fail Limits	Proc	Save/Delete Procedure	<table style="width: 100%; border-collapse: collapse;"> <tr><td style="border: 1px solid black; padding: 2px;">Exec</td><td>Execution Cond</td></tr> <tr><td style="border: 1px solid black; padding: 2px;">Cnfg</td><td>External Devices</td></tr> <tr><td style="border: 1px solid black; padding: 2px;">Print</td><td>Printer Setup</td></tr> <tr><td style="border: 1px solid black; padding: 2px;">IBASIC</td><td>IBASIC Cntrl</td></tr> </table>	Exec	Execution Cond	Cnfg	External Devices	Print	Printer Setup	IBASIC	IBASIC Cntrl		
Freq	Channel Information																				
Parm	Test Parameters																				
Seqn	Order of Tests																				
Spec	Pass/Fail Limits																				
Proc	Save/Delete Procedure																				
Exec	Execution Cond																				
Cnfg	External Devices																				
Print	Printer Setup																				
IBASIC	IBASIC Cntrl																				

TESTS (Save/Delete Procedures)

SAVE/DELETE TEST PROCEDURE:

Select Procedure Location:

Enter Procedure Filename:

Enter Description for New Procedure:

SAVE PROCEDURE INFORMATION:

Procedure Library:

Code Location:

Password

<p>1 <input type="button" value="Save Proc"/></p> <p>2 <input type="button" value="Del Proc"/></p> <p>3 <input type="button" value="Init Card"/></p> <p>4 <input type="button" value="Help"/></p> <p>5 <input type="button" value="Main Menu"/></p>	<p>To Screen</p> <p><input type="radio"/> CDMA <input checked="" type="button" value="CALL CNTL"/></p> <p><input type="radio"/> Analog <input checked="" type="button" value="RX TEST"/></p> <p><input type="radio"/> Config <input checked="" type="button" value="TESTS"/></p>
---	--

3. Select the location where the test procedure file to be deleted is stored.

a. Position the cursor at the **Select Procedure Location:** field and select it.

b. In the **Choices:** menu, position the cursor at the mass storage location where the test procedure file to be deleted is stored and select it.

TESTS (Save/Delete Procedures)

1 Save Proc

2 Del Proc

3 Init Card

4 Help

5 Main Menu

Choices:

Card

RAM

Disk

SAVE/DELETE TEST PROCEDURE:

Select Procedure Location:

Card

Enter Procedure Filename:

Enter Description for New Procedure:

SAVE PROCEDURE INFORMATION:

Procedure Library:

Current/[No Lib]

Chapter 3, Customizing a Test Procedure
Deleting A Test Procedure

4. Select the name of the test procedure file to be deleted.

a. Position the cursor at the **Enter Procedure Filename:** field and select it.

b. In the **Choices:** menu, position the cursor at the name of the test procedure file to be deleted and select it.

c. Select **Done** from the **Choices:** menu to terminate the entry.

The screenshot shows the 'TESTS (Save/Delete Procedures)' menu. The 'Enter Procedure Filename:' field is highlighted with a white arrow pointing to it from the left. The 'Enter Description for New Procedure:' field is also highlighted with a white arrow pointing to it from the left. The 'Choices:' menu is open, and the 'Done' option is highlighted with a white arrow pointing to it from the left. The 'Choices:' menu options are: Done, Position, Over/Ins, Delete, Del End, Bk Space, A, and B. The 'Code Location:' field is set to 'Card'.

TESTS (Save/Delete Procedures)

1 Save Proc

2 Del Proc

3 Init Card

4 Help

5 Main Menu

Choices:

Done

Position

Over/Ins

Delete

Del End

Bk Space

A

B

Enter Procedure Filename:

Enter Description for New Procedure:

SAVE PROCEDURE INFORMATION:

Procedure Library:

Current/[No Lib]

Code Location:

Card

5. Delete the test procedure file.

- a. Position the cursor at the **Del Proc** field and select it, or press USER key K2 .
- b. Select the YES key to delete the test procedure.

TESTS (Save/Delete Procedures)

SAVE/DELETE TEST PROCEDURE:

Select Procedure Location:
Card

Enter Procedure Filename:
[REDACTED]

Enter Description for New Procedure:
[REDACTED]

SAVE PROCEDURE INFORMATION:

Procedure Library:
Current/[No Lib]

Code Location:
Card

1	Save Proc
2	Del Proc
3	Init Card
4	Help
5	Main Menu

Choices:

CDMA
CALL CNTL

Analog
RX TEST

Config

Securing (and Un-securing) A Test Procedure

Test procedures may be secured by storing them in the Test Set's ROM. Securing a test procedure prevents unauthorized viewing and changing of channel information, test parameters, order of tests, and pass/fail limits. You can select the items you wish to secure.

Any test procedure can be secured and un-secured. All test procedures are shipped un-secured.

The process for securing a test procedure is as [follows](#):

1. Activate the Tests Subsystem.

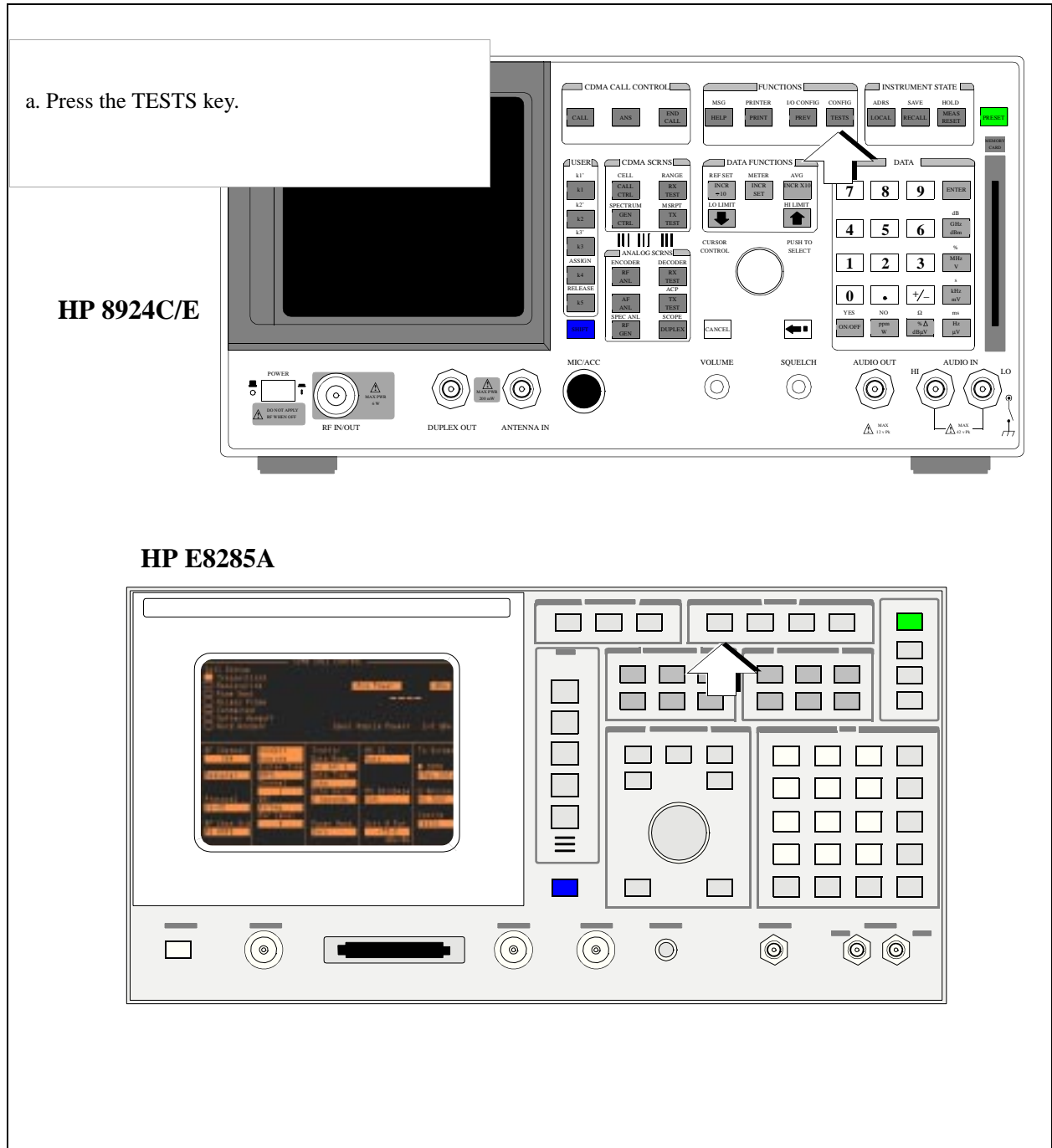

2. Select the Test Set's ROM.

a. Position the cursor at the **Select Procedure Location:** field and select it.

b. In the **Choices:** menu, position the cursor at **ROM** and select it.

TESTS (Main Menu)

a procedure to load.

1 Run Test

2 Continue

4 Help

LOAD TEST PROCEDURE:

Select Procedure Location:

Select Procedure Filename: Library: Program:

Description:

Choices:

Card

ROM

RAM

Disk

3. Select the Test Set's IBASIC utility program.

- a. Position the cursor at the **Select Procedure Filename:** field and select it.
- b. In the **Choices:** menu, position the cursor at **IB_UTIL** and select it.

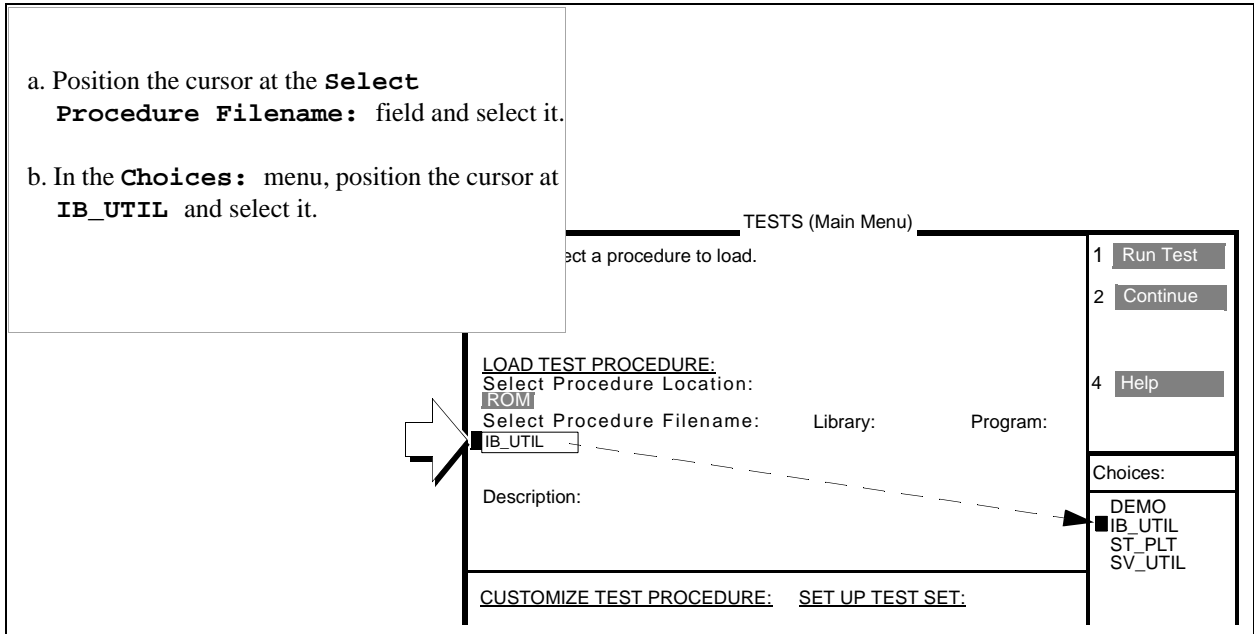

Chapter 3, Customizing a Test Procedure
 Securing (and Un-securing) A Test Procedure

4. Run the IBASIC utility program.

a. Select USER key K1 or position the cursor at **Run Test** and select it.

b. The TESTS (IBASIC Controller) screen will be displayed when the utility program has finished loading.

TESTS (Main Menu)

8217A Software Name

Procedure: Location: Filename: Library: Program:

Description:

CUSTOMIZE TEST PROCEDURE: SET UP Test Set:

Freq	Channel Information	Exec	Execution Cond
Parm	Test Parameters	Cnfg	External Devices
Seqn	Order of Tests	Print	Printer Setup
Spec	Pass/Fail Limits	IBASIC	IBASIC Cntrl
Proc	Save/Delete Procedure		

To Screen

CDMA
CALL CNTL

Analog
RX TEST

Config
TESTS

TESTS (IBASIC Controller)

IB_UTIL

Please select one:

COPY_PL
FILE_XFER
RAM_MANAGER
RAM_USAGE
SECURE_IT
EXIT

This program will copy procedures and libraries from one card to another.

To Screen

CDMA
CALL CNTL

Analog
RX TEST

Config
TESTS

94

S:\HP83217A\USRGUIDE\BOOK\Chapters\3custom.fb

5. Select the security subprogram.

a. Position the cursor at **SECURE_IT** and select it.

The screenshot shows a menu titled "TESTS (IBASIC Controller)" with a sub-menu "IB_UTIL". The menu items are: COPY_PL, FILE_XFER, RAM_MANAGER, RAM_USAGE, SECURE_IT (highlighted with a cursor), and EXIT. A callout box points to SECURE_IT with the text "a. Position the cursor at SECURE_IT and select it." Another callout box next to SECURE_IT says "Secure or unsecure procedure files. If a file is secured the user must know the password." On the right, there is a "To Screen" section with radio buttons for "CDMA" and "Analog", and buttons for "CALL CNTL" and "RX TEST". A vertical list on the right has five numbered items (1-5) with corresponding buttons.

TESTS (IBASIC Controller)

IB_UTIL

Please select one:

- COPY_PL
- FILE_XFER
- RAM_MANAGER
- RAM_USAGE
- SECURE_IT
- EXIT

Secure or unsecure procedure files. If a file is secured the user must know the password.

To Screen

- CDMA
- CALL CNTL
- Analog
- RX TEST

1 []

2 []

3 []

4 []

5 []

6. Select the location of the test procedure to be secured (or un-secured).

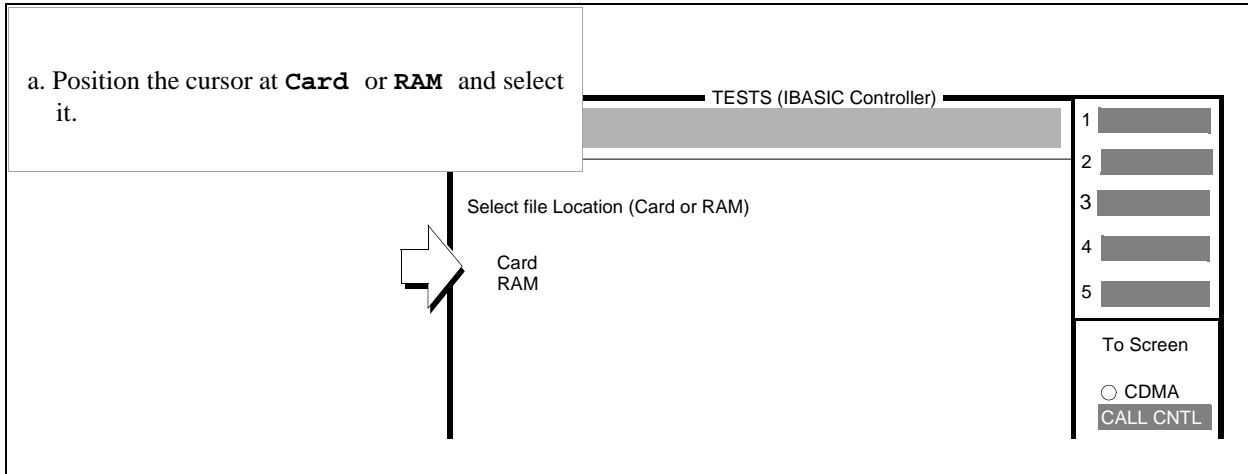

7. Select the name of the test procedure to be secured (or un-secured).

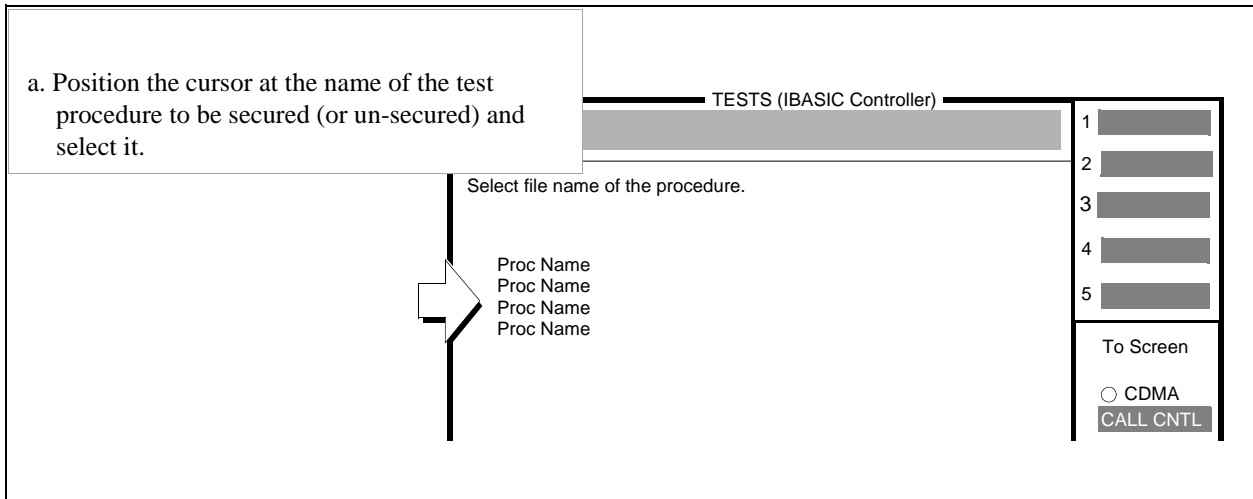

8. Select the test procedure components to secure (or un-secure).

a. Proceed with the on-line instructions. You may select one, some or all of the test procedure components to secure (or un-secure).

b. When all desired components have been secured (or un-secured), position the cursor at the **Done** field and select it (if the **Done** field is not displayed, position the cursor at the **More** field

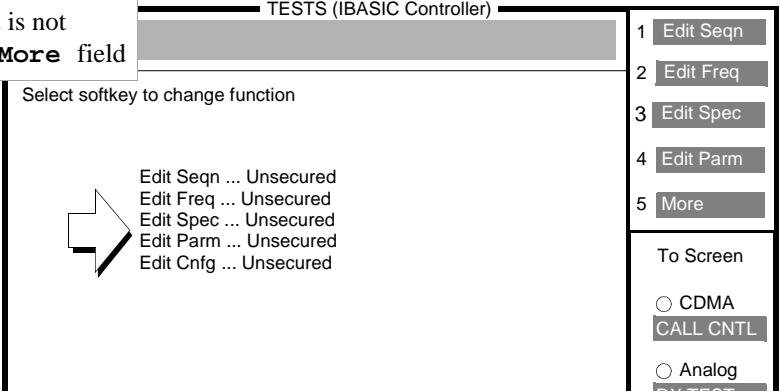

The screenshot shows the 'TESTS (IBASIC Controller)' screen. At the top, there is a header 'TESTS (IBASIC Controller)'. Below it, a list of components is displayed, each followed by 'Unsecured':

- Edit Seqn ... Unsecured
- Edit Freq ... Unsecured
- Edit Spec ... Unsecured
- Edit Parm ... Unsecured
- Edit Cnfg ... Unsecured

A mouse cursor is pointing at the 'Edit Cnfg ... Unsecured' line. To the right of the list, there is a softkey menu with the following options:

- 1 Edit Seqn
- 2 Edit Freq
- 3 Edit Spec
- 4 Edit Parm
- 5 More

Below the softkey menu, there is a 'To Screen' section with radio buttons for 'CDMA' and 'Analog', and a 'CALL CNTL' button.

NOTE: The information in the TESTS (External Devices) screen for a *currently* loaded test procedure may be secured by selecting the **Edit Cnfg** component. However, the information in the TESTS (External Devices) screen is not saved in a test procedure file.

9. Enter the security password.

- a. Use the DATA keys to enter up to a nine-digit numeric security password.
- b. Press the ENTER key to terminate the entry.

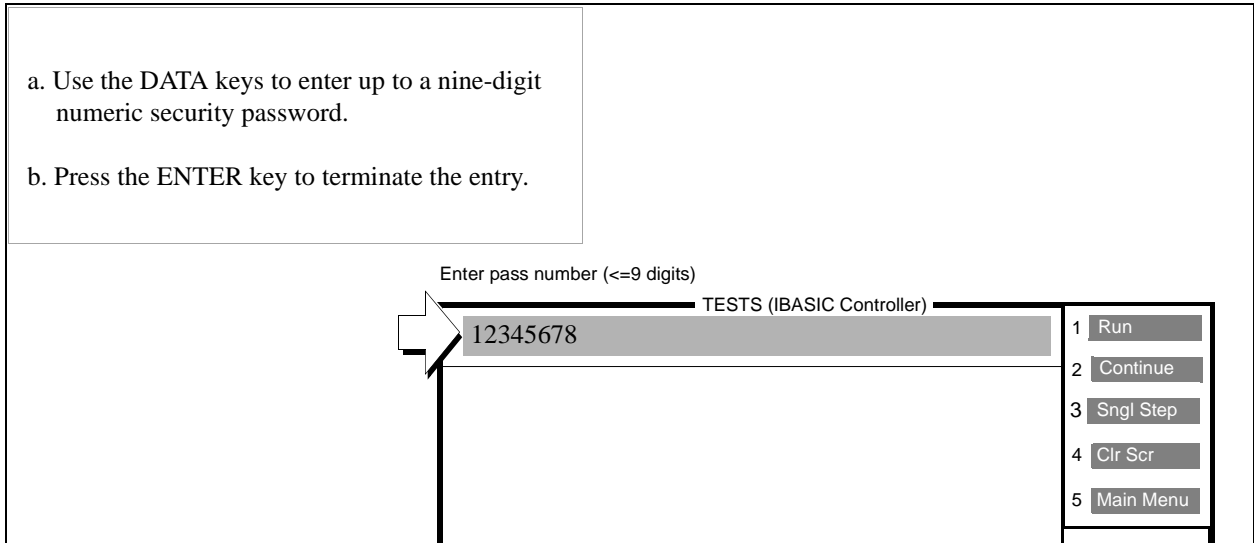

10. Exit the SECURE_IT subprogram.

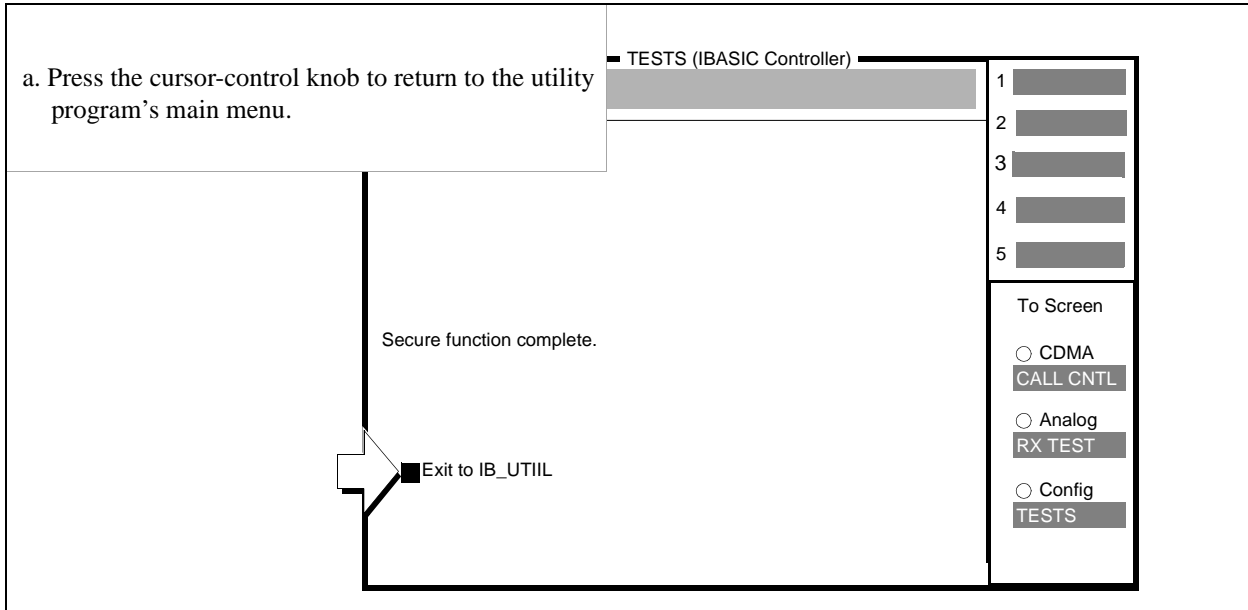

11. Exit the utility program.

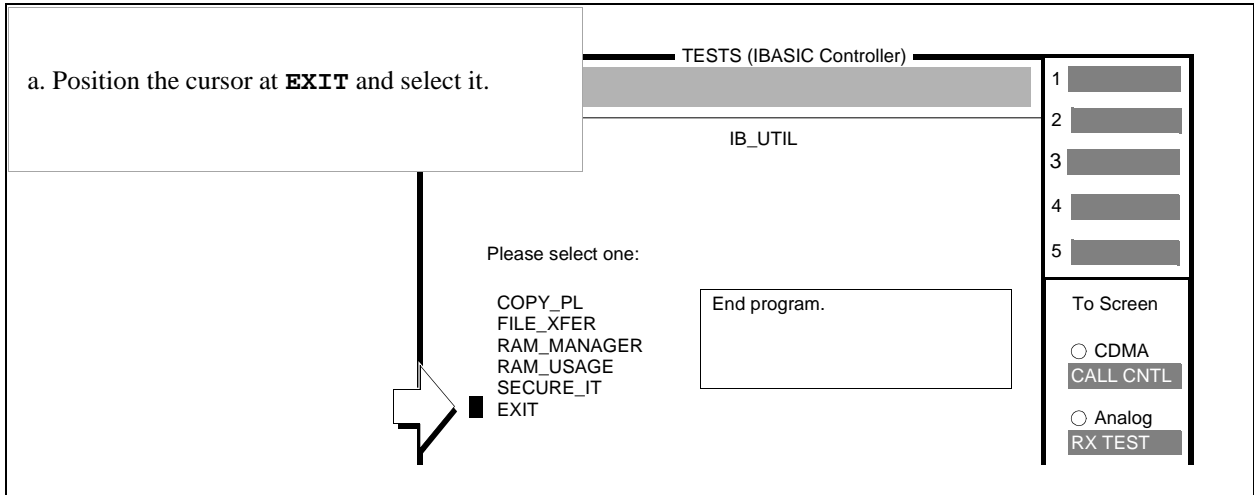

Chapter 3, Customizing a Test Procedure
Securing (and Un-securing) A Test Procedure

Setting Up the Test Set for External Devices

To Configure an External Printer

The information necessary for the software to configure an external printer is entered into the following screens:

- TESTS (Printer Setup)
- TESTS (Execution Conditions)
- TESTS (External Devices)
- I/O CONFIGURE

The [following example](#) shows how to configure an external printer.

1. From the TESTS (Main Menu) screen select the screen for setting up a printer.

a. Position the cursor at the **Printer Setup** field and select it.

b. Verify that the TESTS (Printer Setup) screen appears.

TESTS (Main Menu)

P 83217A Software Name

TEST PROCEDURE:
 Procedure Location: _____
 Procedure Filename: _____ Library: _____ Program: _____

Description: _____

CUSTOMIZE TEST PROCEDURE: SET UP TEST SET:

<table border="0" style="width: 100%;"> <tr><td style="padding-right: 5px;">Freq</td><td>Channel Information</td></tr> <tr><td style="padding-right: 5px;">Parm</td><td>Test Parameters</td></tr> <tr><td style="padding-right: 5px;">Seqn</td><td>Order of Tests</td></tr> <tr><td style="padding-right: 5px;">Spec</td><td>Pass/Fail Limits</td></tr> <tr><td style="padding-right: 5px;">Proc</td><td>Save/Delete Procedure</td></tr> </table>	Freq	Channel Information	Parm	Test Parameters	Seqn	Order of Tests	Spec	Pass/Fail Limits	Proc	Save/Delete Procedure	<table border="0" style="width: 100%;"> <tr><td style="padding-right: 5px;">Exec</td><td>Execution Cond</td></tr> <tr><td style="padding-right: 5px;">Cnfg</td><td>External Devices</td></tr> <tr><td style="padding-right: 5px;">Print</td><td>Printer Setup</td></tr> <tr><td style="padding-right: 5px;">IBASIC</td><td>IBASIC Cntrl</td></tr> </table>	Exec	Execution Cond	Cnfg	External Devices	Print	Printer Setup	IBASIC	IBASIC Cntrl
Freq	Channel Information																		
Parm	Test Parameters																		
Seqn	Order of Tests																		
Spec	Pass/Fail Limits																		
Proc	Save/Delete Procedure																		
Exec	Execution Cond																		
Cnfg	External Devices																		
Print	Printer Setup																		
IBASIC	IBASIC Cntrl																		

1 Run Test

2 Continue

4 Help

To Screen

CDMA
CALL CNTL

Analog
RX TEST

Config
TESTS

TESTS (Printer Setup)

Output Results To:

Output Results For:

Output Heading:

<u>PRINT SETUP:</u>	<u>PAGE CONTROL:</u>
Model: <input type="text" value="Quiet Jet"/>	Lines/Page: <input type="text" value="60"/>
Printer Port: <input type="text" value="Serial"/>	FF at Start: <input type="text" value="Yes/No"/>
	FF at End: <input type="text" value="Yes/No"/>

1 Instrt Ins

2 Delete Ins

4 Help

5 Main Menu

To Screen

CDMA
CALL CNTL

Analog
RX TEST

Config
TESTS

2. Select where to output measurement results.

a. Position the cursor at the **Output Results To:** field and select CRT or Printer.

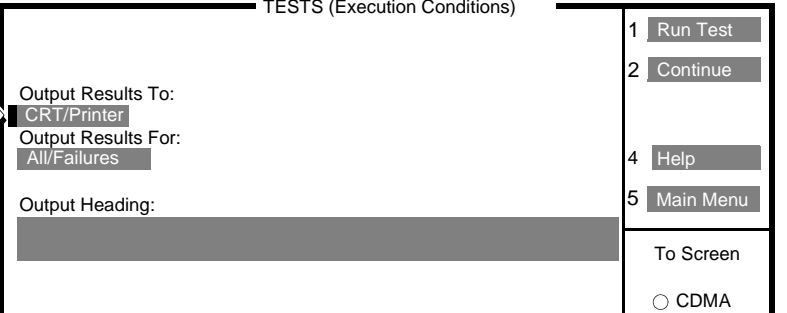

TESTS (Execution Conditions)

Output Results To:
CRT/Printer

Output Results For:
All/Failures

Output Heading:

1 Run Test
2 Continue
4 Help
5 Main Menu

To Screen
 CDMA

Output Results To:

When you select Printer, measurement results will be printed on the display portion of the TESTS (IBASIC Controller) screen and the external printer connected to the Test Set. You must connect and configure a printer if you select Printer. (The default setting is Crt.)

3. Select whether to output only measurement results that fail.

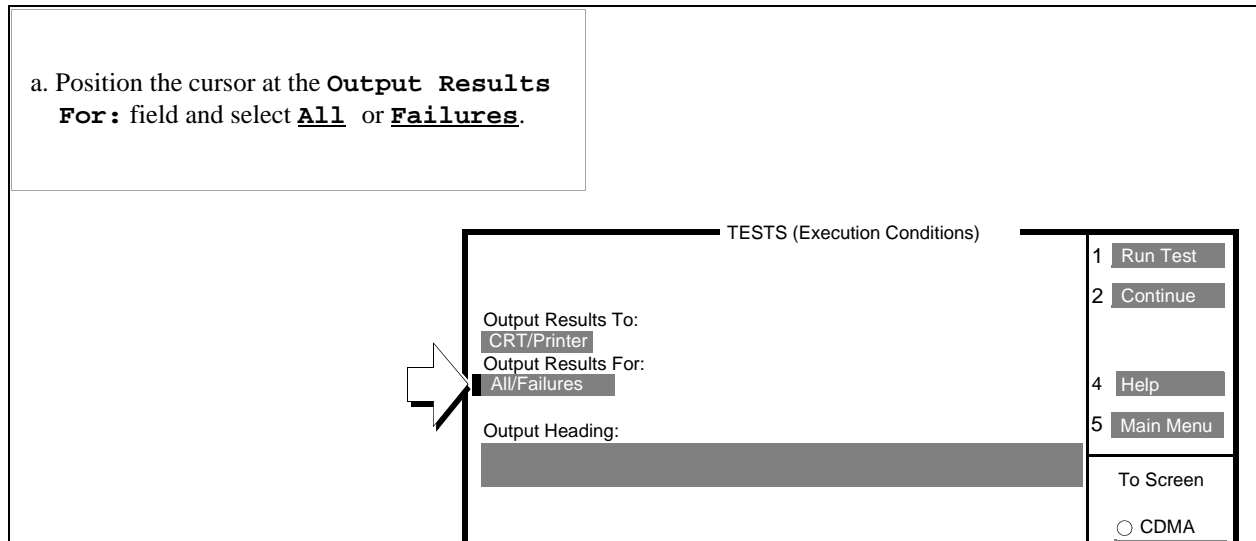

Output Results For:

You can select either **All** or **Failures**. Default: **All**

If you select **All**, all measurement results will be printed.

If you select **Failures**, only measurement results that fail the pass/fail limits will be printed. Printing only failed measurement results is useful if you want to ensure that failed results are documented.

4. Enter an output heading.

a. Position the cursor at the **Output Heading:** field and select it.

b. From the **Choices:** menu, select the letters to enter the heading information, then select **Done**.

The screenshot shows the 'TESTS (Execution Conditions)' menu. The 'Output Heading:' field is highlighted with a grey bar. A white arrow points to the start of this field, and a dashed line with a white arrowhead points from the 'Choices:' menu to the end of the field. The 'Choices:' menu is open, showing options: Done, Position Over/Ins, Delete, Del End, Bk Space, A, B, and C. The 'C' option is currently selected.

TESTS (Execution Conditions)

1 Run Test

2 Continue

4 Help

5 Main Menu

Choices:

Done

Position Over/Ins

Delete

Del End

Bk Space

A

B

C

Output Results To:
CRT/Printer

Output Results For:
All/Failures

Output Heading:

If Unit-Under-Test Fails:
Continue/Stop

Test Procedure Run Mode:
Continuous/Single Step

Output Heading:

You can use this field to enter a heading, of up to 100 characters, that will be printed at the top of each page of measurement results.

The **Output Heading:** field consists of two independent 50 character fields. Position the cursor on the upper field to enter up to 50 characters. Position the cursor on the lower field to enter up to 50 characters. You must select **Done** at the end of each field.

5. Select a supported printer.

a. Position the cursor at the **Model** field and select it.

b. Select a printer from the list of supported printers.

The screenshot shows a printer configuration menu. The 'PRINT SETUP:' section includes fields for 'Model' (highlighted with a cursor), 'Printer Port', and 'Serial'. The 'PAGE CONTROL:' section includes fields for 'Lines/Page', 'FF at Start', 'FF at End', and 'Yes/No'. A list of printer models is shown on the right, including HP ThinkJet, HP QuietJet, HP PaintJet, HP DeskJet, HP LaserJet, Epson FX-80, and Epson LQ-850. A dashed arrow points from the 'Model' field to the list of printer models.

Unsupported Printers

If you do not have one of the supported printers, consult your printer's manual for possible printer settings to emulate one of the supported printers.

6. Select the correct printer interface for the external printer.

a. Position the cursor at the **Printer Port:** field and select it.

b. Select the correct interface type for the printer selected in the **Model** field.

TESTS (Printer Setup)

Output Heading:

PRINT SETUP:

Model: Quiet Jet

Printer Port: Serial

PAGE CONTROL:

Lines/Page: 60

FF at Start: Yes/No

FF at End: Yes/No

1 Insrt Ins

2 Delete Ins

4 Help

5 Main Menu

Choices:

Serial

HP-IB

Parallel

a. If **HP-IB** is selected as the printer interface then position the cursor at the **Printer Adrs** field and select it.

b. Enter the HP-IB address of the printer selected in the **Model** field.

TESTS (Printer Setup)

PRINT SETUP:

Model: Quiet Jet

Printer Port: HPIB

Printer Adrs: 1

PAGE CONTROL:

Lines/Page: 60

FF at Start: Yes/No

FF at End: Yes/No

7. Configure the PAGE CONTROL fields.

<p>a. Position the cursor at the Lines/Page: field and select it.</p> <p>b. Enter the number of lines you wish to be printed on each page.</p> <p>c. Position the cursor at the FF at Start: field and select it.</p> <p>d. Select Yes if you want a form feed (FF) command sent to the external printer at the beginning of each measurement results printout.</p> <p>e. Position the cursor at the FF at End field and select it.</p> <p>f. Select Yes if you want a form feed (FF) command sent to the external printer at the end of each measurement results printout.</p>	<p>TESTS (Printer Setup)</p> <p>To:</p> <p>For:</p> <p>1 Insrt Ins</p> <p>2 Delete Ins</p> <p>4 Help</p> <p>5 Main Menu</p> <p>To Screen</p> <p><input type="radio"/> CDMA CALL CNTL</p> <p><input type="radio"/> Analog RX TEST</p> <p><input type="radio"/> Config TESTS</p> <p>PAGE CONTROL:</p> <p>Lines/Page: 60</p> <p>FF at Start: Yes/No</p> <p>FF at End: Yes/No</p>
--	---

8. Specify the escape sequences necessary to configure the printer.

Some printers require escape sequences to configure them for printing options such as print pitch, margin size, lines per inch, paper size, and so forth. If the selected printer's default print options are acceptable or if the selected printer does not require any configuration [skip this step](#).

The necessary escape sequences are entered in the TESTS (External Devices) screen. Refer to the selected printer's user's manual for the available print features and corresponding escape sequences.

The escape sequences entered into the TESTS (External Devices) screen are sent to the printer whenever the software is run (the **Run** or **Run Test** softkeys are pressed). The escape sequences entered into the TESTS (External Devices) screen are *not* sent to the printer when the front-panel PRINT key is pressed. The [following sub-steps](#) show how to specify the escape sequence.

Step 8A.

- a. Position the cursor at the **External Devices** field and select it.
- b. Verify that the TESTS (External Devices) screen appears.

TESTS (Main Menu)

P 83217A Software Name

PROCEDURE:
 Procedure Location: _____
 Procedure Filename: _____ Library: _____ Program: _____

CUSTOMIZE TEST PROCEDURE: SET UP TEST SET:

Freq	Channel Information	Exec	Execution Cond
Parm	Test Parameters	Cnfg	External Devices
Seqn	Order of Tests	Print	Printer Setup
Spec	Pass/Fail Limits	IBASIC	IBASIC Cntrl
Proc	Save/Delete Procedure		

1	Run Test
2	Continue
4	Help
To Screen	
<input type="radio"/>	CDMA
	CALL CNTL
<input type="radio"/>	Analog
	RX TEST
<input type="radio"/>	Config
	TESTS

TESTS (External Devices)

Inst#	Calling Name Options	Model	Addr	
				1 Insrt Ins
				2 Delete Ins
				3 Print All
				4 Help
				5 Main Menu
				To Screen
				<input type="radio"/> CDMA
				CALL CNTL
				<input type="radio"/> Analog
				RX TEST
				<input type="radio"/> Config
				TESTS

External Disk Specification

:700,0

S:\HP83217A\USRGUIDE\BOOK\Chapters\4extdev.fb

113

Chapter 4, Setting Up the Test Set for External Devices
To Configure an External Printer

Step 8B.

- a. Position the cursor at the **Inst#** field and select it.
- b. Rotate the knob until an unused instrument number field is displayed and select it..

The screenshot shows a menu titled "TESTS (External Devices)". The menu has five columns: "Inst#", "Calling Name Options", "Model", "Addr", and a fifth column with numbered options. The "Inst#" field contains the number "1" and has a cursor pointing to it. Below the "Inst#" field are the numbers 2, 3, 4, and 5. The fifth column contains the following options: 1 Instrt Ins, 2 Delete Ins, 3 Print All, 4 Help, and 5 Main Menu. Below these options is a section titled "To Screen" with a radio button next to "CDMA" and a button labeled "CALL CNTL".

Inst#	Calling Name Options	Model	Addr	
1				1 Instrt Ins
				2 Delete Ins
				3 Print All
				4 Help
				5 Main Menu

To Screen

CDMA

CALL CNTL

Step 8C.

- a. Position the cursor at the **Calling Name** field and select it.
- b. Select **Escape Sequence** from the **Choices** menu.
- c. Select **Done** to enter the choice.

The screenshot shows a menu titled "TESTS (External Devices)". The menu has a header with "Calling Name" and "Options" underlined. Below the header, there are five numbered options: 1. ESCAPE SEQUENCE, 2. [blacked out], 3. [blacked out], 4. [blacked out], and 5. [blacked out]. A mouse cursor is pointing at option 1. To the right of the menu, there is a vertical list of five buttons: 1. Insr Ins, 2. Delete Ins, 3. Print All, 4. Help, and 5. Main Menu. Below the menu, there is a "Choices:" section with a dashed border. It contains three options: DATA COLLECTION, POWER SUPPLY, and ESCAPE SEQUENCE. The ESCAPE SEQUENCE option is highlighted with a mouse cursor. A dashed line connects the ESCAPE SEQUENCE option in the "Choices:" section to the ESCAPE SEQUENCE option in the main menu.

Chapter 4, Setting Up the Test Set for External Devices To Configure an External Printer

Step 8D.

- a. Position the cursor at the **Addr** field and select it.
- b. Using the DATA keys enter, the address for your printer.

TESTS (External Devices)			
Inst#	Calling Name Options	Model	Addr
1	ESCAPE SEQUENCE		01
2			
3			
4			
5			

1 Insrt Ins
2 Delete Ins
3 Print All
4 Help
5 Main Menu

To Screen
 CDMA
CALL CNTL

Adrs

- Enter **9** for serial printers
- Enter **15** for parallel printers
- Enter **7XX** for HP-IB printers (XX = printer address, such as 01)

Step 8E.

a. Position the cursor at the **Options** field and select it.

b. If applicable, select a pre-defined escape sequence from the **Choices** menu, or enter an appropriate sequence using the list of characters below the pre-defined choices.

c. Select **Done** to enter the choices.

TESTS (External Devices)		
Calling Name	Model	Addr
Options		

1	ESCAPE SEQUENCE	01	1	Insr	Ins
2	&166P~		2	Delete	Ins
3			3	Print	All
4			4	Help	
5			5	Main Menu	

Choices:

&166P

&172

&16D

&18D

(s12h12c6T)

Options

When sending escape sequences to the selected printer, the software automatically sends an escape character as the first character in the sequence. If entering two or more escape sequences into the field, use the ~ (tilde) as a place holder for the escape character between each sequence. The software will automatically replace the ~ with an escape character when sending the escape sequences to the printer.

The software comes with a set of predefined escape sequences which are compatible with HP printers. The predefined escape sequences are listed in ["Escape Sequences for HP Printers" on page 183](#).

If the desired escape sequence exceeds the **Options** field length (22 characters), break the sequence into two or more sequences and enter each sequence into a separate **Options** field. The calling name **Escape Sequence** must be entered in the **Calling Name** field and the appropriate address must be entered in the **Addr** field for all escape sequence entries.

9. Set the Test Set's I/O configuration for the selected printer.

- a. Press and release the SHIFT key, then press the PREV key to display the I/O CONFIGURE screen.
- b. If **HP-IB** is selected as the printer port,
 1. Position the cursor at the **Mode** field and select it.
 2. Select **Control** from the **Choices:** menu.
- c. If **Serial** is selected as the printer port,
 1. Position the cursor at the **Serial Baud** field and select it.
 2. Enter the baud rate for the external printer.
 3. Set the other serial communications fields listed under the **Serial Baud** field to correspond to the external printer's configuration.

I/O CONFIGURE	
HP-IB Adrs 14	Serial Baud 9600
Mode Talk&Lstn	Parity None
	Data Length 8 bits
	Stop Length 1 bit
Save/Recall Internal	Rcv Pace XOn/XOff
	Xmt Pace XOn/XOff
	To Screen
	<input type="radio"/> CDMA CALL CNTL
	<input type="radio"/> Analog RX TEST
	<input type="radio"/> Config TESTS

10. Connect the external printer to the Test Set.

"Connecting an HP-IB Printer" on page 120

"Connecting a Serial Printer (HP 8924C/E)" on page 121

"Connecting a Serial Printer (HP E8285A)" on page 123

"Connecting a Parallel Printer" on page 123

Chapter 4, Setting Up the Test Set for External Devices To Configure an External Printer

Connecting an HP-IB Printer

Connect an HP-IB printer to the Test Set's rear-panel HP-IB connector.

HP 8924C/E

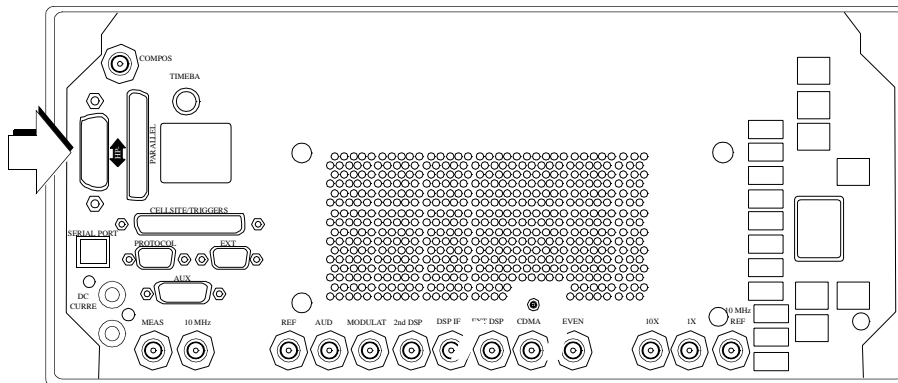

HP E8285A

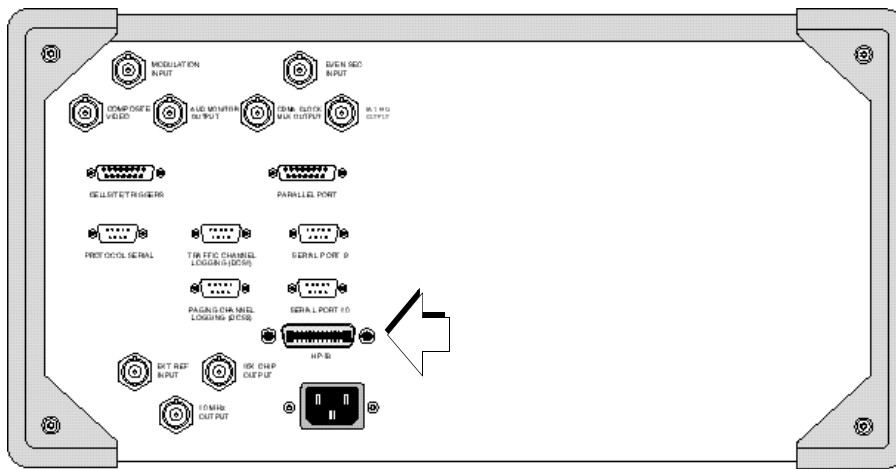

Connecting a Serial Printer (HP 8924C/E)

Connect a serial printer to the Test Set's rear-panel RJ-11 jack with the appropriate serial cable for your printer. **Figure 3** shows the pinouts for the RJ-11 connector.

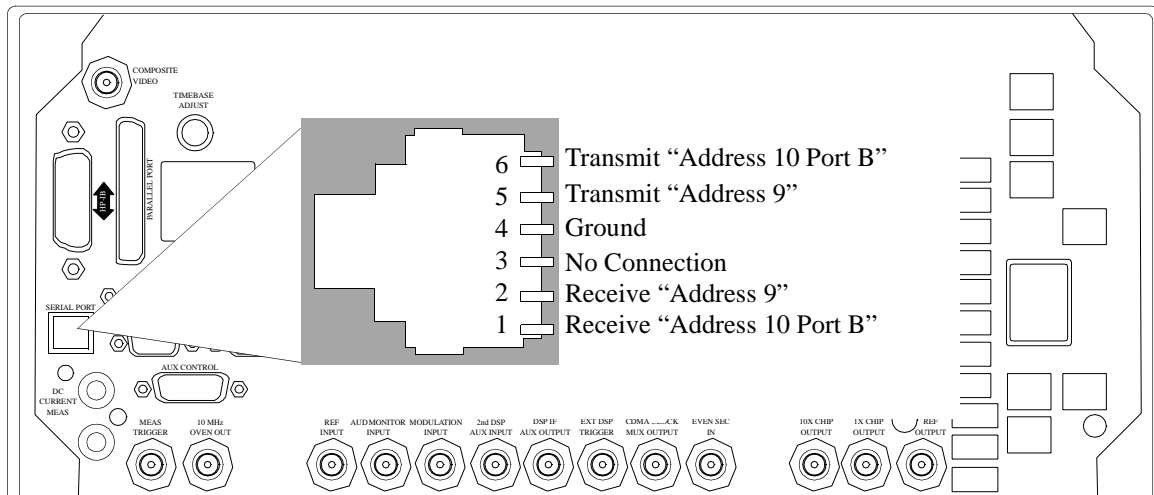

Figure 3 Serial Printer connection (HP 8924C/E)

If using a serial printer, you cannot use the serial port 9 for other connections at the same time, such as Data Collection (saving test results).

Use 98642-66508) and RJ-11 cable (HP P/N 98642-66505) to connect the Test Set to a serial printer.

RJ-11 CONNECTORS RJ-11 cables and adapters can be wired several ways. If you buy a cable or adapter other than the HP parts listed, verify that the connections are the same as those shown in **table 3 on page 122** before connecting the adapters and/or cables to the Test Set.

Table 3 lists connections for Transmit, Receive, and Ground pins for serial port 9.

Table 3 Pinouts for 25 Pin and 9 Pin RS-232 Cables

From HP 8924C RJ-11 Serial Port	To 25-Pin RS-232 Connector	To 9-Pin RS-232 Connector
pin 2 (RX)	pin 2 (TX)	pin 3 (TX)
pin 5 (TX)	pin 3 (RX)	pin 2 (RX)
pin 4 (GND)	pin 7 (GND)	pin 5 (GND)

Connecting a Serial Printer (HP E8285A)

Connect a serial printer to the Test Set's rear-panel Serial Port 9 connector with the appropriate serial cable for your printer.

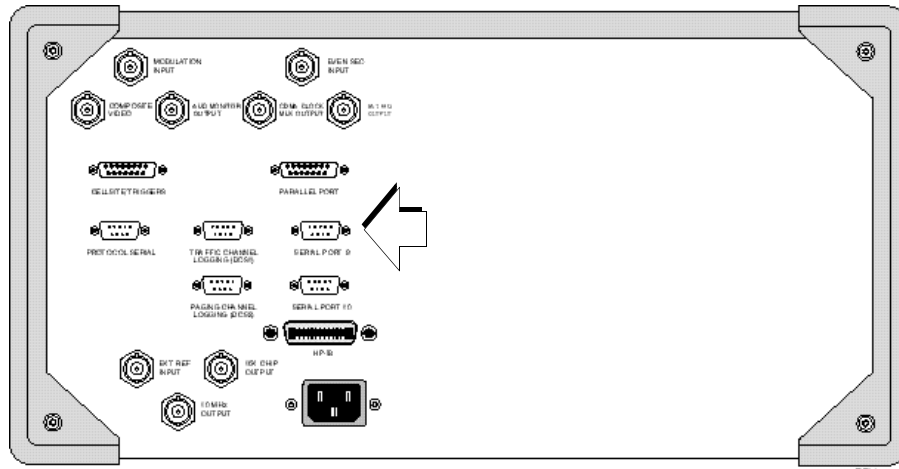

Figure 4

Serial Printer connection (HP E8285A)

Connecting a Parallel Printer

Connect a parallel printer to the Test Set's rear-panel parallel connector with the appropriate parallel cable for your printer. [Figure 5, "Parallel Printer connection," on page 124](#) shows the pinouts for the Test Set's rear panel parallel connector.

Chapter 4, Setting Up the Test Set for External Devices
 To Configure an External Printer

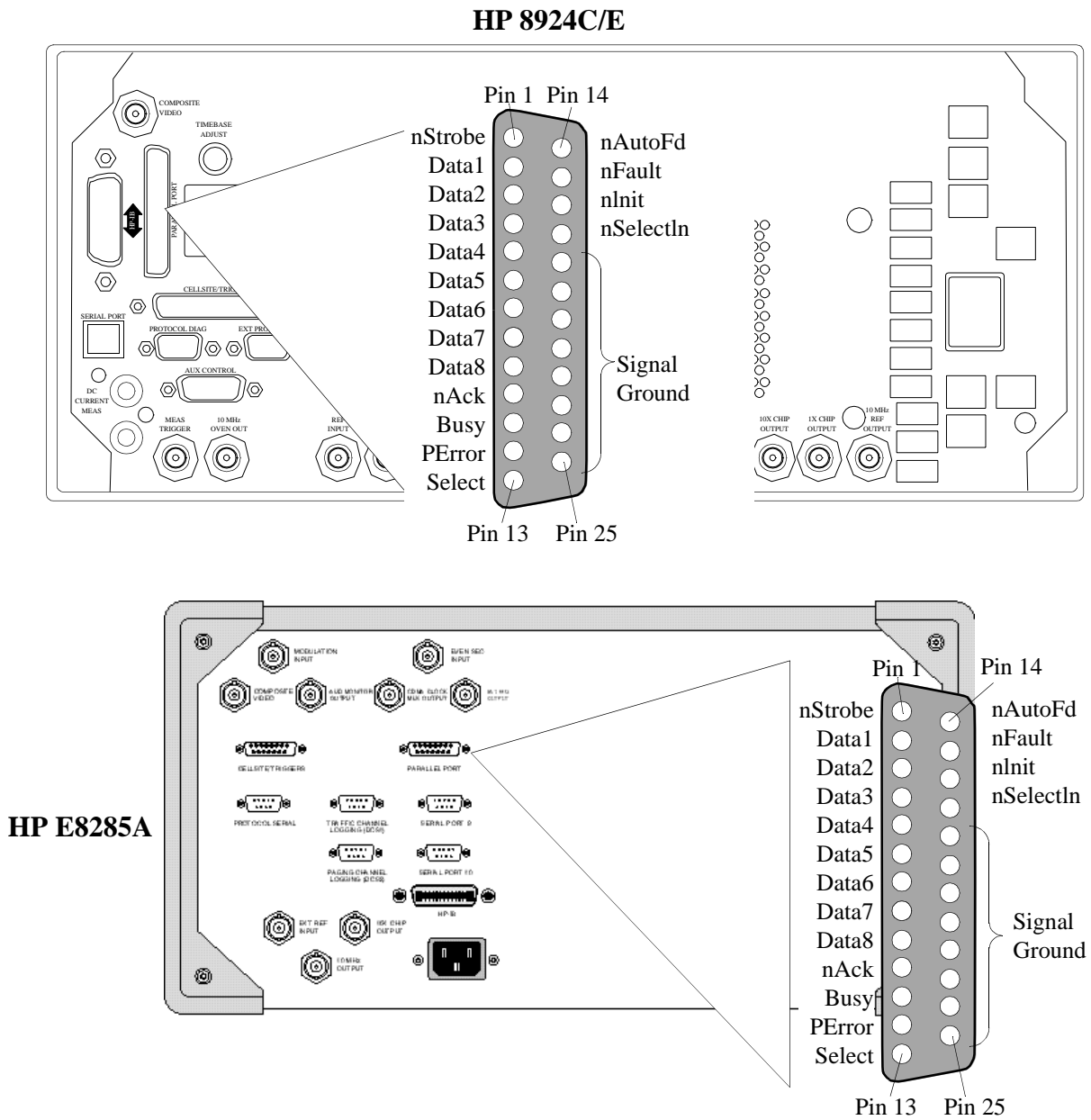

Figure 5 Parallel Printer connection

11. Verify the printer's connection.

- a. Select the PRINT key. (Shifted function on the HP E8285A).
- b. A copy of the screen should be output to the external printer.

If printing does not occur recheck your setup.

HP 8924C/E

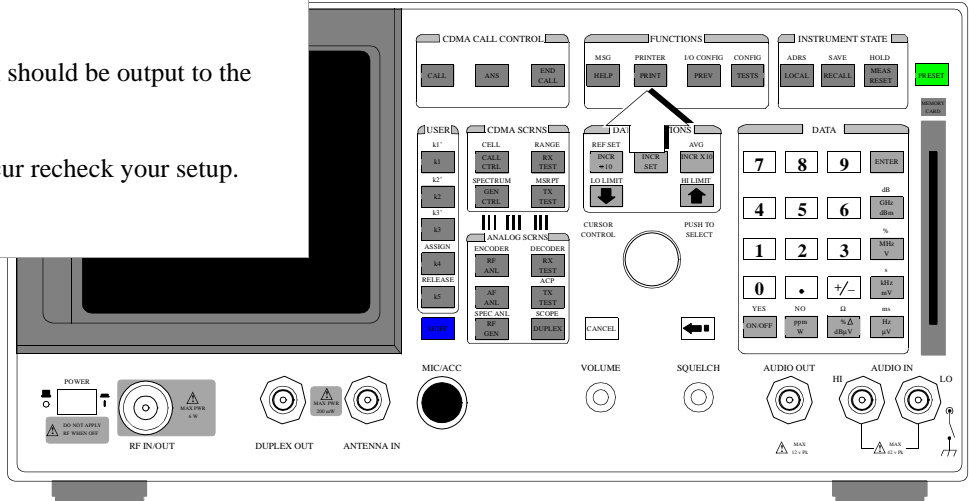

HP E8285A

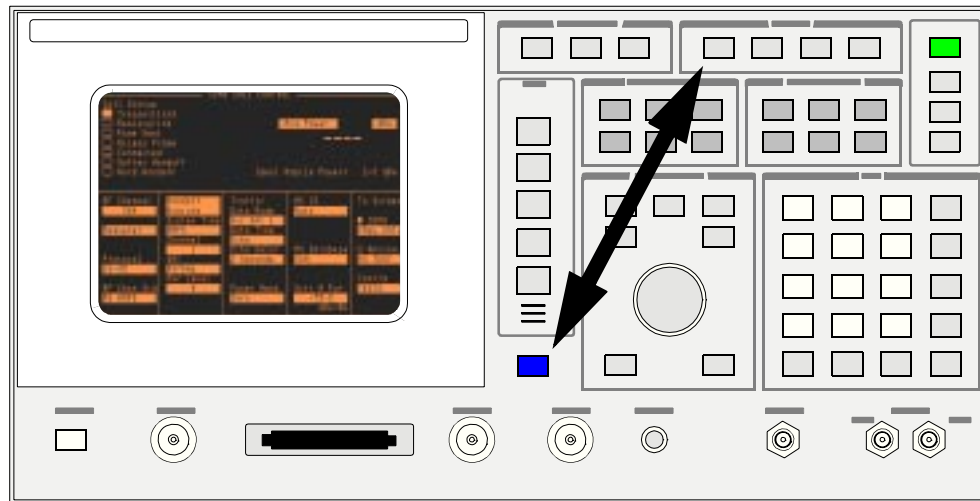

To Configure a Programmable Power Supply

A Hewlett-Packard HP-IB programmable power supply can be added to the test system configuration. The information necessary for the software to access an external power supply is entered into the TESTS (External Devices) screen.

The software has the capability to make tests at normal, high, and low supply voltages to the mobile-station-under-test. If you want to perform normal, high, and low supply voltage testing automatically, a Hewlett-Packard programmable dc power supply with appropriate voltage and current capabilities from the following series is required:

- HP 664xA
- HP 665xA
- HP 667xA
- HP 668xA

NOTE:

HP 662xA and HP 663xA series dc power supplies are not supported.

A dc power supply with the ability to produce the high supply voltage setting at the mobile station's maximum current draw is required.

This [example procedure](#) is provided to show how to make selections on the **TESTS (External Devices)** screen, it does not cover connecting the programmable power supply to the Test Set. Refer to the power supply's user's guide for connection information.

1. Select the screen for configuring external devices.

a. Position the cursor at the **External Devices** field and select it.

b. Verify that the TESTS (External Devices) screen appears.

TESTS (Main Menu)

P 83217A Software Name

TEST PROCEDURE:
 Procedure Location: _____
 Procedure Filename: _____ Library: _____ Program: _____

Description: _____

CUSTOMIZE TEST PROCEDURE: SET UP TEST SET:

Freq	Channel Information	Exec	Execution Cond
Parm	Test Parameters	Cnfg	External Devices
Seqn	Order of Tests	Print	Printer Setup
Spec	Pass/Fail Limits	IBASIC	IBASIC Cntrl
Proc	Save/Delete Procedure		

TESTS (External Devices)

<u>Inst#</u>	<u>Calling Name</u> <u>Options</u>	<u>Model</u>	<u>Addr</u>	
2				1 Insrt Ins
3				2 Delete Ins
4				3 Print All
5				4 Help
				5 Main Menu

External Disk Specification

:.700,0

To Screen

CDMA
CALL CNTL

Analog
RX TEST

Config
TESTS

2. Select an unused instrument number field.

a. Position the cursor at the Inst# field and select it.

b. Rotate the knob until an unused instrument number field is displayed and select it.

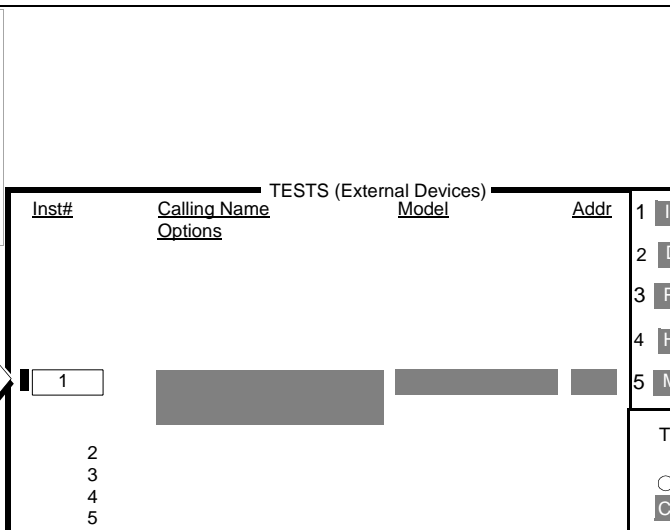

TESTS (External Devices)			
<u>Inst#</u>	<u>Calling Name Options</u>	<u>Model</u>	<u>Addr</u>
1			
2			
3			
4			
5			

3. Enter the pre-defined calling name.

a. Position the cursor at the **Calling Name** field and select it.

b. In **Choices:** menu, position the cursor at the pre-defined calling name **POWER SUPPLY** and select it.

c. Select **Done** to enter the pre-defined name.

TESTS (External Devices)		Addr	1	Insrt	Ins
Calling Name	Model		2	Delete	Ins
Options			3	Print	All
			4	Help	
			5	Main Menu	

2

3

4

5

POWER SUPPLY

Choices:

- Done
- Position
- Over/Ins
- Delete
- Del End
- Bk Space
-
- DATA COLLECTION
- POWER SUPPLY
- ESCAPE
- SEQUENCE

External Disk Specification

.,700,0

4. Select the model number of the power supply.

a. Position the cursor at the **Model** field and select it.

b. From the **Choices:** menu, select the model number of the power supply from the list of supported models.

c. Select **Done** to enter the power supply's model number.

Calling Name	Model	Addr
	HP6642A	

2
3
4
5

Choices:
HP6642A
HP6643A
HP6652A
HP6653A
HP6654A
HP6655A
HP6672A

1 Insrt Ins
2 Delete Ins
3 Print All
4 Help
5 Main Menu

5. Enter the HP-IB address of the power supply.

a. Position the cursor at the **Addr** field and select it.

b. Use the DATA keys to enter the address of the mass storage device.

c. Select the ENTER key to enter the address number.

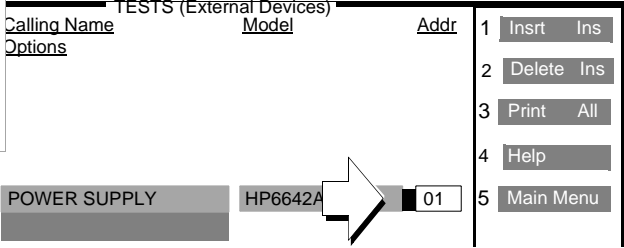

The screenshot shows a menu titled "TESTS (External Devices)" with columns for "Calling Name", "Model", and "Addr". A row is highlighted with "POWER SUPPLY" in the "Calling Name" column, "HP6642A" in the "Model" column, and "01" in the "Addr" column. A white arrow points to the "01" in the "Addr" field. To the right of the menu is a vertical list of function keys: 1 Insrt Ins, 2 Delete Ins, 3 Print All, 4 Help, and 5 Main Menu.

6. Connect the power supply to the HP-IB connector on the rear panel of the Test Set.

Refer to the power supply's user's guide for connection information.

Using an External PC or Terminal

This section describes how to connect the Test Set to an external PC with a “terminal emulator” application or a terminal. This setup has the following uses:

- Input IBASIC programming commands to the Test Set’s command line.
- Display stored measurement results on a PC display.

A “terminal emulator” is an application program running on the PC that can communicate with the Test Set through one of the PC’s serial communication ports. It provides a bidirectional means of sending and receiving ASCII characters to the Test Set’s serial port 9 or serial port 10.

An ANSI-compatible terminal like the Digital Equipment Corporation VT-100 can also be used to directly communicate with the Test Set.

Configuring the Test Set for Terminal or PC Operation

It is preferable to enter long strings of characters into fields using a keyboard attached to a terminal/computer. The characteristics of the serial port, when used for instrument control from a terminal or terminal emulator, are determined by settings on the Test Set’s I/O CONFIGURE screen.

On the I/O CONFIGURE screen, make the following settings:

- **Serial In** (HP 8924C/E) or **Serial_9 In** (HP E8285A) fields to **Inst.**
- **IBASIC Echo** field to **On**
- **Inst Echo** field to **On**

Set the remaining configuration entries to match the settings of your terminal or PC program.

Configuring the Test Set's Serial I/O Port

Serial I/O interfaces

There are two serial I/O interfaces on the Test Set's rear-panel. On the HP 8924C/E the two serial interfaces are available through an RJ-11 connector. On the HP E8285A the two serial interfaces are available through separate 9-pin sub-miniature D connectors. The serial I/O ports are designated by interface select codes nine and ten. Each interface uses a 3-wire transmit/receive/ground implementation of the RS-232 standard. An explanation of these interfaces is given in "[Serial Port Information](#)" on page 196.

Test Set Settings

Under the **To screen** menu, select **More**, then select **IO CONFIG**. Set the following fields, shown in [table 4](#), to their recommended settings.

Table 4 Test Set Serial Port 9 Configuration

Field	Available Settings	Recommended Setting
Serial In (HP 8924C/E) or Serial_9 In (HP E8285A)	Inst/IBASIC	Inst (routes character input to serial port 9 to the IBASIC Command Line field)
IBASIC Echo	On/Off	On (routes characters, such as messages or character output from PRINT or DISPLAY commands, to serial port 9)
Inst Echo	On/Off	On (echoes characters sent to the Test Set back to the PC).
Serial Baud Rate	150, 300, 600, 1200, 2400, 4800, 9600, 19200	9600
Parity	None, Odd, Even, Always 1, Always 0	None
Data Length	7 bits, 8 bits	8 bits
Stop Length	1 bit, 2 bits	1 bit
Rcv Pace (HP 8924C/E only)	None, Xon/Xoff	Xon/Xoff
Xmt Pace (HP 8924C/E only)	None, Xon/Xoff	Xon/Xoff
Flow Cntl (HP E8285A only)	None, Xon/Xoff, Hardware	Xon/Xoff

NOTE: These settings will be retained by the Test Set if the PRESET key is pressed, the *RST command is sent, or the power is cycled. These settings may change, however, if certain test procedures are run.

The Test Set has a serial port input buffer length of 2000 characters. Buffer size becomes important when IBASIC programs expect to receive large amounts of data through the serial port with a single ENTER statement.

Configuring an External PC

Connecting the cable

Connect the Test Set's Serial Port 9 to a serial I/O port on the PC.

If you are using an HP 8924C/E, use a cable as shown in [figure 6](#) . (On many PCs, a serial port is available as either a 25-pin DB-25 (female) connector or a 9-pin DB-9 (male) connector). There are serial cables and adapters that are available from HP. See [figure 7](#) for details.

If you are using an HP E8285A, connect a serial cable from the PC to the Test Set's rear panel SERIAL PORT 9 connector.

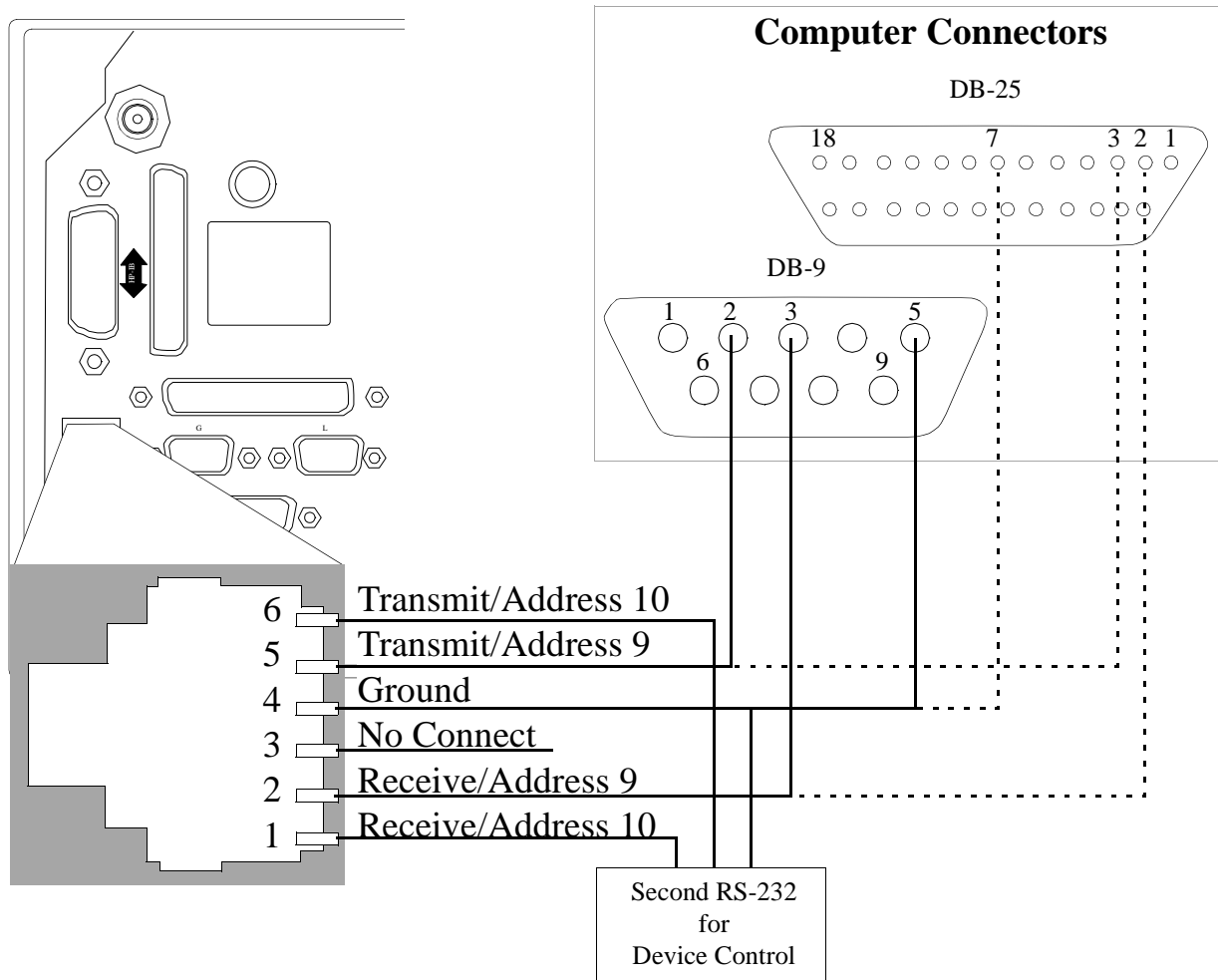

Figure 6 Connecting the HP 8924C/E Serial Port to a PC or Terminal

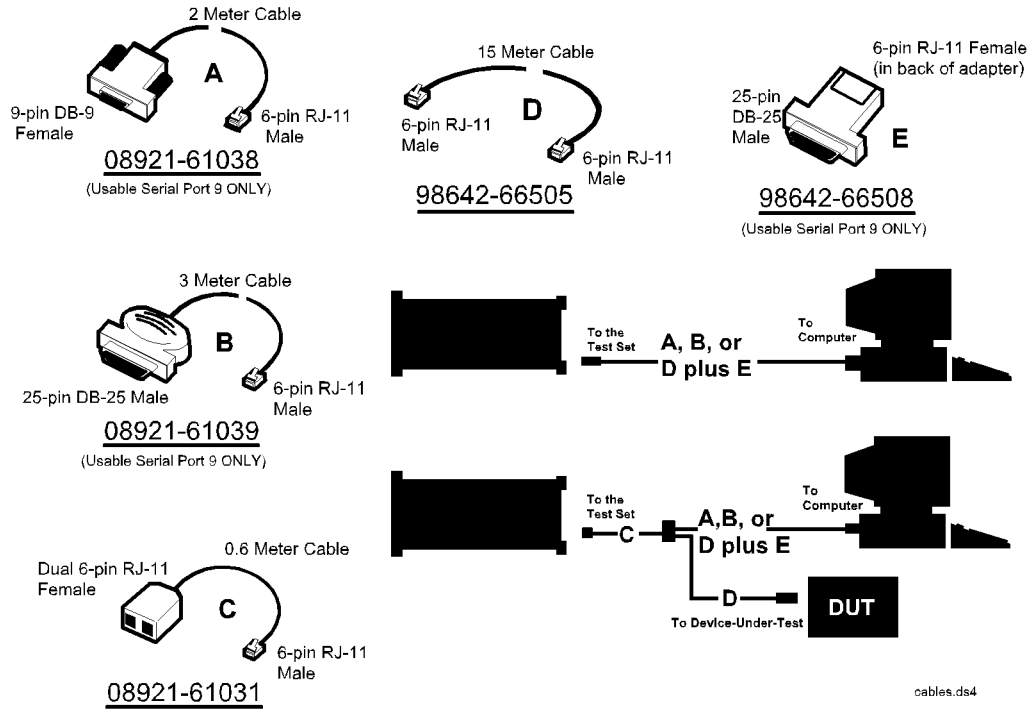

Figure 7 Available HP RS-232 Serial Cables and Adapters

Configuring a Terminal Emulator

The terminal emulator application must be configured to match the following settings on the Test Set's I/O CONFIGURE screen:

- Serial Baud (Baud Rate)
- Parity
- Data Length (Data bits)
- Stop Length (Stop bits)
- Rcv Pace (Flow Control)
- Xmt Pace (Flow Control)

The terminal emulator application must also be configured to match the serial I/O port on the PC. This could be one of the following choices, depending on the external PC:

- COM 1
- COM 2
- COM 3
- COM 4

The following sections describe setups for several popular terminal emulators.

Setting Up ProComm Revision 2.4.3 on your PC

ProComm is a general purpose telecommunications software package for PC's with MS-DOS. One of its functions is to provide an RS-232 terminal function on a typical PC.

Procedure for Running ProComm in MSDOS (You can use ProComm's built-in help function to learn more).

1. To access the help and command functions, press the Alt and F10 keys simultaneously (abbreviated as Alt+F10).
2. Press the space bar to move among the choices for a particular field.
3. Press ENTER to accept the displayed choice.

Procedure for Setting up the ProComm Software

1. Press Alt+ P to access the LINE SETTINGS window.
2. Enter the number **11**. This will automatically set the following:
 - Baud rate: **9600**
 - Parity: **None**
 - Data Bits: **8**
 - Stop Bits: **1**
 - Selected communications port: **COM1** (This may be different on your PC)
3. To select a different communications port, enter the following numbers:
 - 20: **COM1**
 - 21: **COM2**
 - 22: **COM3**
 - 23: **COM4**
4. Enter the number 24 to save changes, to make the new configuration your default, and to exit LINE SETTINGS.
5. Press Alt+S for the SETUP MENU.
6. Enter the number 1 for MODEM SETUP.
7. Enter the number 1 for the Modem init string.
8. Press Enter to set a null string.
9. Press Esc to exit MODEM SETUP back to the SETUP MENU.
10. Enter the number 2 for TERMINAL SETUP.
11. Terminal emulation: **VT-100**
 - Duplex: **FULL**
 - Flow Control: **XON/XOFF**
 - CR translation (in): **CR**
 - CR translation (out): **CR**
 - BS translation: **NON-DEST**
 - BS key definition: **BS**
 - Line wrap: **ON**
 - Scroll: **ON**
 - Break length (ms): **350**
 - Enquiry (CNTL-E): **OFF**
12. Press Esc to exit Terminal Setup back to the Setup Menu.
13. Enter the number 4 for General Setup.
 - Translate Table: **OFF**
 - Alarm sound: **OFF**
 - Alarm time (seconds): **1**
 - Aborted downloads: **KEEP**
14. Press Esc to exit General Setup back to the Setup Menu.
15. On the Setup Menu, press S to save your entries.
16. Press Esc to exit the Setup Menu.
17. Press Alt+X to exit ProComm back to MS-DOS.

Setting Up HP AdvanceLink (HP 68333F Version B.02.00) on your PC

HP AdvanceLink is a software program which allows PCs to be used as an alphanumeric or graphics terminal. It can also automate terminal and file-transfer functions. The version described will work with PCs with the MS-DOS or PC-DOS operating systems. (AdvanceLink for Windows is also available, and configuration is very similar).

Procedure for Running AdvanceLink in MSDOS

1. Press the Tab key to move from one field to the next, which also accepts the displayed choice.
2. Press the NEXT CHOICE and PREVIOUS CHOICE keys to move among the choices for a particular field.

Procedure for Setting up the AdvanceLink Software

1. Press the TERMINAL function key.
2. Press CONFIG KEYS.
3. Press GLOBAL CONFIG.
 - Keyboard: **USASCII**
 - Personality: **ANSI**
 - Language: **ENGLISH**
 - Terminal Mode: **Alphanumeric**
 - Remote To: enter your PC's selected serial port number, often, **Serial 1**
 - Printer I/F: **None**
 - Memory Size: **32K**
 - Plotter I/F: **None**
 - Video Type: **select your display type**
 - Forms Path: **no entry**
 - Screen Size: **select your size - 23 or 24**
4. Press DONE to return to the Config screen.
5. Press REMOTE CONFIG (to set up the Serial port you selected above in Remote To).
 - Baud Rate: **9600**
 - Parity/DataBits: **None/8**
 - Enq Ack: **NO**
 - Asterisk: **OFF**
 - Chk Parity: **NO**
 - SR(CH): **LO**
 - Recv Pace: **Xon/Xoff**
 - CS(CB)Xmit: **NO**
 - XmitPace: **Xon/Xoff**

Chapter 4, Setting Up the Test Set for External Devices Using an External PC or Terminal

6. Press DONE to return to the Config screen.
7. Press TERMINAL CONFIG.
 - Terminal Id: **2392A**
 - LocalEcho: **OFF**
 - CapsLock: **OFF**
 - Start Col: **01**
 - Bell: **ON**
 - XmitFnctn(A): **NO**
 - SPOW(B): **NO**
 - InhEolWrp(C): **NO**
 - Line/Page(D): **LINE**
 - InhHndShk(G): **NO**
 - Inh DC2(H): **NO**
 - Esc Xfer(N): **YES**
 - ASCII 8 Bits: **YES**
 - Fld Separator: **down arrow or US**
 - BlkTerminator: **up arrow or RS**
 - ReturnDef: **musical note or CR**
 - Copy: **Fields**
 - Type Ahead: **NO**
 - Row Size: **160**
 - Host Prompt Character: **left arrow or D1**
 - Horiz. Scrolling Increment: **08**
8. Press DONE to return to the Config screen.
9. Press DONE to return to the Terminal screen.
10. Press MAIN to return to the Main screen.
11. Press EXIT ADVLINK to exit.

Configuring a Terminal

Use the cable information in [table 4 on page 134](#) and [figure 7 on page 137](#) for connecting to an external terminal. Terminals typically have a DB-25 (male) connector. Set the terminal for DEC VT-100 ANSI emulation. Many ASCII terminals will also function properly.

To set up the terminal, use the field settings found in the HP AdvanceLink terminal emulator section found earlier in this chapter. As a minimum, make sure the terminal's basic setup information matches the fields on the Test Set's I/O CONFIGURE screen (refer to [table 4 on page 134](#) for recommended settings).

Chapter 4, Setting Up the Test Set for External Devices Using an External PC or Terminal

Setting Up the Test Set for Data Collection

This chapter explains the methods for saving and retrieving test result data.

To Set Up for Data Collection

NOTE:

External HP-IB disk drives are not recommended for data collection due to speed limitations of the HP-IB bus. DOS formatted PCMCIA SRAM memory cards or an external PC are the recommended mass storage devices for data collection.

The information necessary to configure the software for data collection is entered into the TESTS (External Devices) screen.

The recommended file system for data collection is DOS. By default, data stored to a DOS-formatted disk will be stored as an ASCII file type. If there is a need to store data to a file system other than DOS, [see "File Types and Sizes" on page 184](#).

The [following procedure](#) shows how to configure the Test Set for data collection.

1. Connect the external device to the appropriate port on the rear panel of the Test Set.

If using an initialized memory card for data collection, go to [step 2](#).

If using an external PC, see ["Using an External PC or Terminal" in chapter 4](#) for connection information and return to step 2.

If using an external disk drive, refer to the disk drive's documentation for connection information and return to step 1a.

1a. If an external disk drive is used, put the Test Set in control mode.

- a. Press then release the blue SHIFT key, then press the PREV key, to display the I/O CONFIGURE screen.
- b. Position the cursor in the **Mode** field and select it.
- c. Select **Control** in the **Mode** field (Make sure there is no other active controller on the HP-IB).

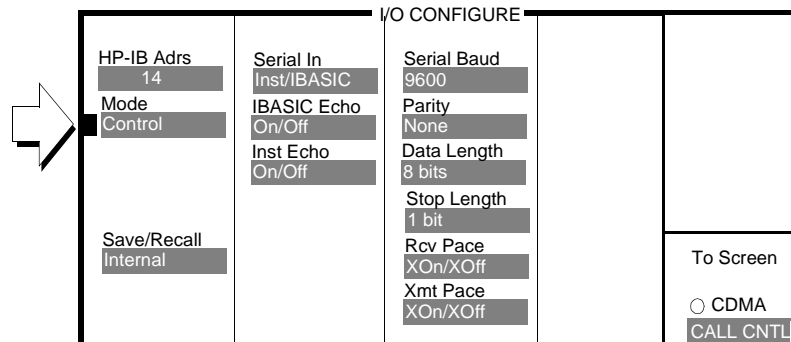

2. Activate the Tests Subsystem.

a. Press the TESTS key.

HP 8924C/E

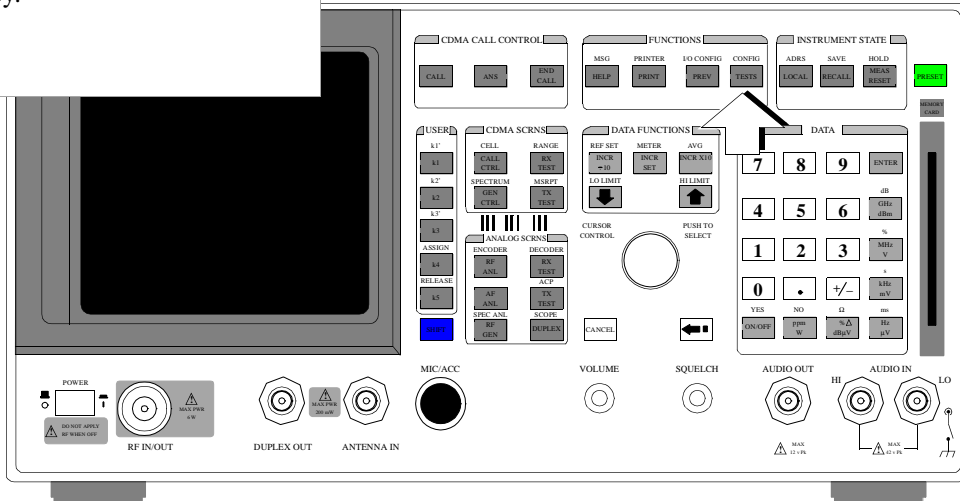

HP E8285A

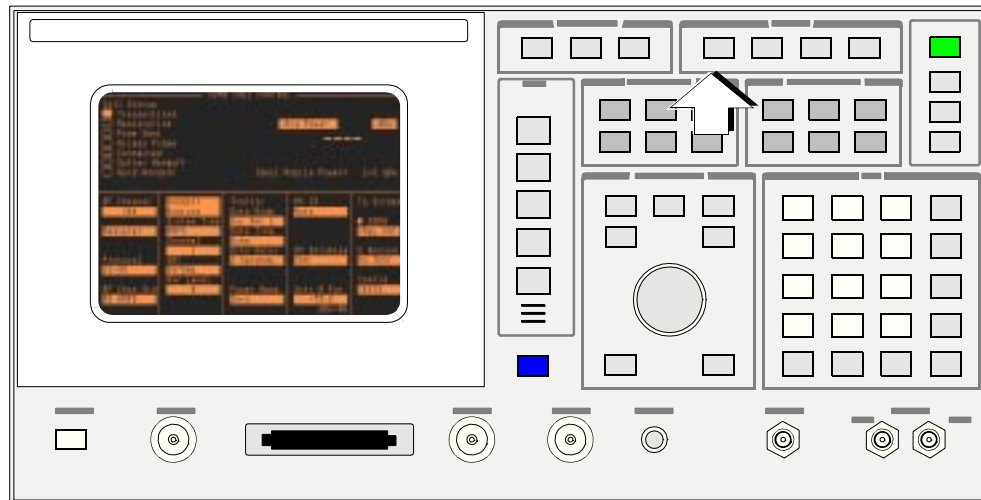

3. Select the TESTS (External Devices) screen.

a. Position the cursor at the **External Devices** field and select it.

b. Verify that the TESTS (External Devices) screen appears.

TESTS (Main Menu)

P 83217A Software Name

TEST PROCEDURE:
 Procedure Location: _____
 Procedure Filename: _____ Library: _____ Program: _____

Description: _____

CUSTOMIZE TEST PROCEDURE: SET UP Test Set:

Freq	Channel Information	Exec	Execution Cond
Parm	Test Parameters	Cnfg	External Devices
Seqn	Order of Tests	Print	Printer Setup
Spec	Pass/Fail Limits	IBASIC	IBASIC Cntrl
Proc	Save/Delete Procedure		

TESTS (External Devices)

Inst#	Calling Name <u>Options</u>	Model	Addr	
1				Instrt Ins
2				Delete Ins
3				Print All
4				Help
5				Main Menu

To Screen

CDMA
CALL CNTL

Analog
RX TEST

Config
TESTS

External Disk Specification

:700,0

4. Select an unused instrument number field.

a. Position the cursor at the **Inst#** field and select it.

b. Rotate the knob until an unused instrument number field is displayed and select it.

Inst#	Calling Name Options	Model	Addr
1			
2			
3			
4			
5			

1 2 3 4 5

5. Enter the pre-defined calling name.

a. Position the cursor at the **Calling Name** field and select it.

b. In the **Choices:** menu, position the cursor at the pre-defined calling name **DATA COLLECTION** and select it, then select **Done**.

TESTS (External Devices)		
Calling Name	Model	Addr
Options		
1	Insr	Ins
2	Delete	Ins
3	Print	All
4	Help	
5	Main Menu	

Choices:

- Done
- Position Over/Ins
- Delete
- Del End
- Bk Space
-
- DATA COLLECTION

External Disk Specification
:.700.0

6. Enter the address of the mass storage device to be used for data collection.

a. Position the cursor at the **Addr** field and select it.

b. Use the DATA keys to enter the address of the mass storage device, see [table 5](#).

c. Select the ENTER key to enter the address.

Mass Storage Addresses

Table 5 Mass Storage Addresses For Data collection

Mass Storage Device	Address	Comments
Sram Memory Card	1	Recommended mass storage device for data collection. DOS format is the recommended file system for data collection.
PC	9	Uses Test Set serial port 9 to connect to external PC. You cannot use serial port 9 for printing and data collection at the same time. See "Using an External PC or Terminal," in chapter 4, on page 133 for further information on using an external PC for data collection.
External HP-IB Disk Drive	7XX XX=physical address of disk drive example: 702	Not recommended for data collection due to: Data transfer speed limitations of the HPIB bus. No volume specifier allowed in address. (Default volume specifier is zero).

7. Enter a DOS file extension (optional).

A DOS file extension can be entered in the **Options** field, however, this step is optional.

You will be prompted for a file name when the test procedure is run, and if no extension exists in the **Options** field, nothing will be appended to the file name when it is created.

a. Position the cursor at the **Options** field and select it.

b. Enter a DOS file extension. The characters must be enclosed in parenthesis. Example: (tst).

c. Select **Done**. Unless you have chosen Address 9, the serial I/O port, the Test Set will prompt you for a file name during the test procedure.

TESTS (External Devices)		
Calling Name	Model	Addr
Options		

DATA COLLECTION		XX
(tst)		

2	3	4	5	
---	---	---	---	--

External Disk Specification	<table border="1" style="width: 100%; border-collapse: collapse;"> <tr> <td style="width: 100%;">1</td> <td style="width: 100%;">Insr</td> <td style="width: 100%;">Ins</td> </tr> <tr> <td>2</td> <td>Delete</td> <td>Ins</td> </tr> <tr> <td>3</td> <td>Print</td> <td>All</td> </tr> <tr> <td>4</td> <td colspan="2">Help</td> </tr> <tr> <td>5</td> <td colspan="2">Main Menu</td> </tr> <tr> <td colspan="3" style="text-align: center;">Choices:</td> </tr> <tr> <td colspan="3">Done</td> </tr> <tr> <td colspan="3">Position</td> </tr> <tr> <td colspan="3">Over/Ins</td> </tr> <tr> <td colspan="3">Delete</td> </tr> <tr> <td colspan="3">Del End</td> </tr> <tr> <td colspan="3">Bk Space</td> </tr> <tr> <td colspan="3">A</td> </tr> <tr> <td colspan="3" style="text-align: center;">█ B</td> </tr> <tr> <td colspan="3">C</td> </tr> </table>	1	Insr	Ins	2	Delete	Ins	3	Print	All	4	Help		5	Main Menu		Choices:			Done			Position			Over/Ins			Delete			Del End			Bk Space			A			█ B			C		
1	Insr	Ins																																												
2	Delete	Ins																																												
3	Print	All																																												
4	Help																																													
5	Main Menu																																													
Choices:																																														
Done																																														
Position																																														
Over/Ins																																														
Delete																																														
Del End																																														
Bk Space																																														
A																																														
█ B																																														
C																																														

To Collect Data (Saving Test Results)

The software has the capability to save test result data to a PCMCIA SRAM memory card (the recommended media) or to a PC.

The [following procedure](#) shows how to save test result data using the data collection feature of the software.

1. Connect the external device and set up the Test Set for data collection.

If the Test Set is not configured for data collection, see ["To Set Up for Data Collection" on page 146](#).

2. Insert a memory card.

["To Initialize a Memory Card \(DOS Format\)" on page 167](#) for more information.

3. Perform the steps required to run the test procedure.

If a test procedure is not loaded, see ["Using the Software" on page 15](#).

4. Enter the data collection file name.

If the Test Set is set up correctly, you will be prompted for a data collection file name. Use the cursor-control knob to select each character, then select **Done** to enter the file name. If you have configured the software for data collection to a PC, you will not be prompted for a file name.

To Retrieve Test Results

The Test Set's ROM disk contains a utility program for retrieving test result data from a PCMCIA SRAM card. The utility program can send the retrieved data to an external PC or terminal through serial port 9 or to an HP-IB printer. See ["Using an External PC or Terminal" on page 133](#) for information on connecting to an external PC or terminal.

The [following procedure](#) shows how to use the utility program to retrieve test result data from a PCMCIA SRAM card inserted into the Test Set's front-panel memory card slot.

1. Activate the Tests Subsystem.

a. Press the TESTS key.

HP 8924C/E

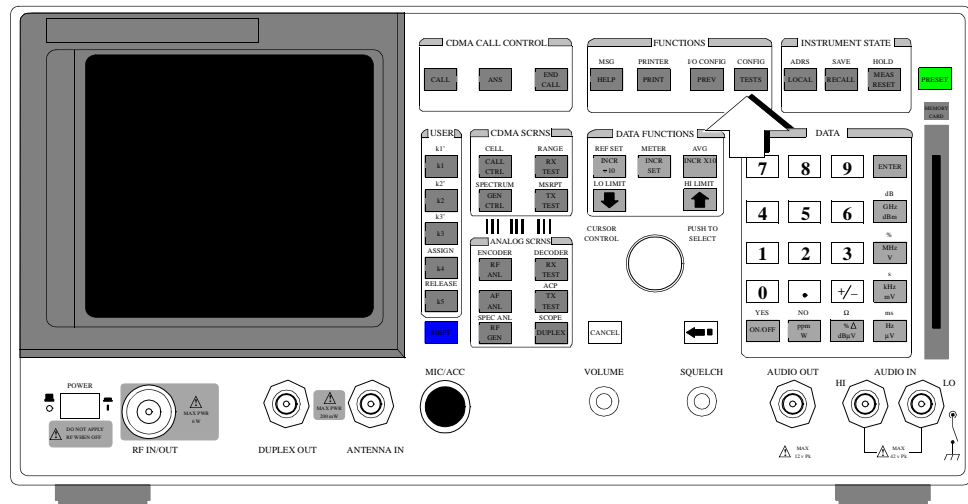

HP E8285A

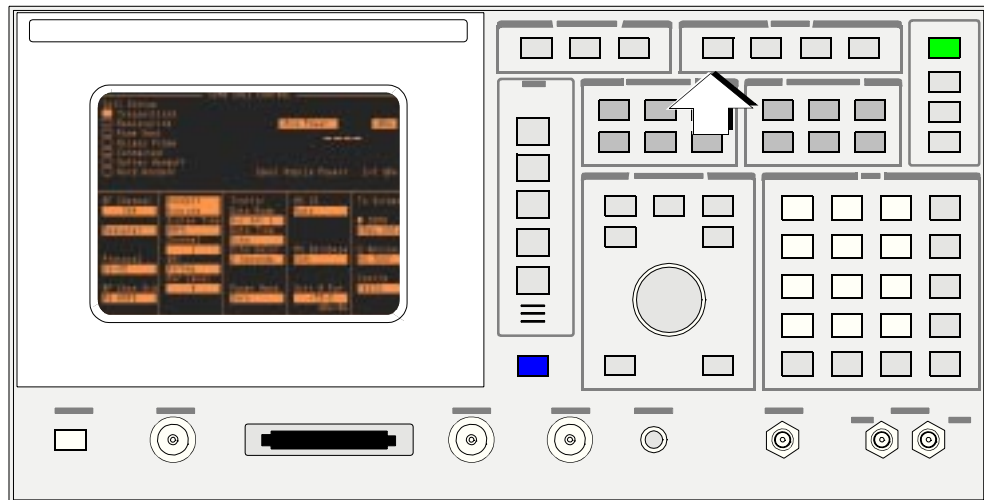

2. Select the location of the supplied IBASIC utility program.

a. Position the cursor at the **Select Procedure Location:** field and select it.

b. In the **Choices:** menu, position the cursor at **ROM** and select it.

TESTS (Main Menu)

a procedure to load.

1 Run Test

2 Continue

4 Help

LOAD TEST PROCEDURE:
Select Procedure Location:

Select Procedure Filename: Library: Program:

Description:

Choices:

Card
ROM
RAM
Disk

The screenshot shows a terminal window with a 'LOAD TEST PROCEDURE' screen. A box on the left contains two instructions: 'a. Position the cursor at the **Select Procedure Location:** field and select it.' and 'b. In the **Choices:** menu, position the cursor at **ROM** and select it.' The screen itself has a title bar 'TESTS (Main Menu)' and a subtitle 'a procedure to load.'. Below this, there are four numbered menu items: '1 Run Test', '2 Continue', '4 Help', and '4 Help'. A 'Choices:' menu is visible at the bottom right, with options 'Card', 'ROM', 'RAM', and 'Disk'. The 'ROM' option is highlighted with a cursor. The main screen has fields for 'Select Procedure Location:', 'Select Procedure Filename:', 'Library:', 'Program:', and 'Description:'. A dashed arrow points from the 'ROM' option in the 'Choices:' menu to the 'Select Procedure Location:' field. A solid arrow points from the 'LOAD TEST PROCEDURE:' title to the 'Select Procedure Location:' field.

3. Select the utility program containing the subprogram used to retrieve test result data.

a. Position the cursor at the **Select Procedure Filename:** field and select it.

b. In the **Choices:** menu, position the cursor at **IB_UTIL** and select it.

TESTS (Main Menu)

Select a procedure to load.

1 Run Test

2 Continue

4 Help

LOAD TEST PROCEDURE:
Select Procedure Location: ROM

Select Procedure Filename: Library: Program:

IB_UTIL

Description:

Choices:

DEMO
■ IB_UTIL
ST_PLT
SV_UTIL

CUSTOMIZE TEST PROCEDURE: SET UP TEST SET:

4. Run the utility program.

a. Select USER key K1 or position the cursor at **Run Test** and select it.

b. The TESTS (IBASIC Controller) screen will be displayed when the test procedure begins to execute.

TESTS (Main Menu)

IB UTIL

Procedure: _____

Location: _____

Filename: _____ Library: _____ Program: _____

Description: _____

CUSTOMIZE TEST PROCEDURE: SET UP Test Set:

<table style="width: 100%; border-collapse: collapse;"> <tr><td style="width: 20px; font-size: 8px;">Freq</td><td style="font-size: 8px;">Channel Information</td></tr> <tr><td style="font-size: 8px;">Parm</td><td style="font-size: 8px;">Test Parameters</td></tr> <tr><td style="font-size: 8px;">Seqn</td><td style="font-size: 8px;">Order of Tests</td></tr> <tr><td style="font-size: 8px;">Spec</td><td style="font-size: 8px;">Pass/Fail Limits</td></tr> <tr><td style="font-size: 8px;">Proc</td><td style="font-size: 8px;">Save/Delete Procedure</td></tr> </table>	Freq	Channel Information	Parm	Test Parameters	Seqn	Order of Tests	Spec	Pass/Fail Limits	Proc	Save/Delete Procedure	<table style="width: 100%; border-collapse: collapse;"> <tr><td style="width: 20px; font-size: 8px;">Exec</td><td style="font-size: 8px;">Execution Cond</td></tr> <tr><td style="font-size: 8px;">Cnfg</td><td style="font-size: 8px;">External Devices</td></tr> <tr><td style="font-size: 8px;">Print</td><td style="font-size: 8px;">Printer Setup</td></tr> <tr><td style="font-size: 8px;">IBASIC</td><td style="font-size: 8px;">IBASIC Cntrl</td></tr> </table>	Exec	Execution Cond	Cnfg	External Devices	Print	Printer Setup	IBASIC	IBASIC Cntrl
Freq	Channel Information																		
Parm	Test Parameters																		
Seqn	Order of Tests																		
Spec	Pass/Fail Limits																		
Proc	Save/Delete Procedure																		
Exec	Execution Cond																		
Cnfg	External Devices																		
Print	Printer Setup																		
IBASIC	IBASIC Cntrl																		

To Screen

CDMA
CALL CNTL

Analog
RX TEST

Config
TESTS

TESTS (IBASIC Controller)

IB_UTIL

Please select one:

COPY_PL This program will
FILE_XFER copy procedures and
RAM_MANAGER libraries from one
RAM_USAGE card to another.
SECURE_IT
EXIT

To Screen

CDMA
CALL CNTL

Analog
RX TEST

Config
TESTS

160

S:\HP83217A\USRGUIDE\BOOK\Chapters\5datac.fb

5. Select the subprogram used to retrieve test result data.

a. Position the cursor at **FILE_XFER** and select it.

The screenshot shows a menu titled "TESTS (IBASIC Controller)" with a sub-menu "IB_UTIL". A list of options is displayed: COPY_PL, FILE_XFER (highlighted with a cursor), RAM_MANAGER, RAM_USAGE, SECURE_IT, and EXIT. A callout box points to FILE_XFER with the text "Please select one:". Another callout box describes FILE_XFER: "Transfers files on the front-panel memory card to HP-IB or serial port A." On the right side, there are five numbered buttons (1-5) and a "To Screen" section with radio buttons for "CDMA" and "Analog", and buttons for "CALL CNTL" and "RX TEST".

TESTS (IBASIC Controller)

IB_UTIL

Please select one:

- COPY_PL
- FILE_XFER
- RAM_MANAGER
- RAM_USAGE
- SECURE_IT
- EXIT

Transfers files on the front-panel memory card to HP-IB or serial port A.

To Screen

- CDMA
- CALL CNTL
- Analog
- RX TEST

6. Insert the memory card containing the test result data to be retrieved.

a. Insert the memory card containing the test result data to be retrieved into the Test Set's front-panel memory card slot.

b. Push the cursor-control knob to continue.

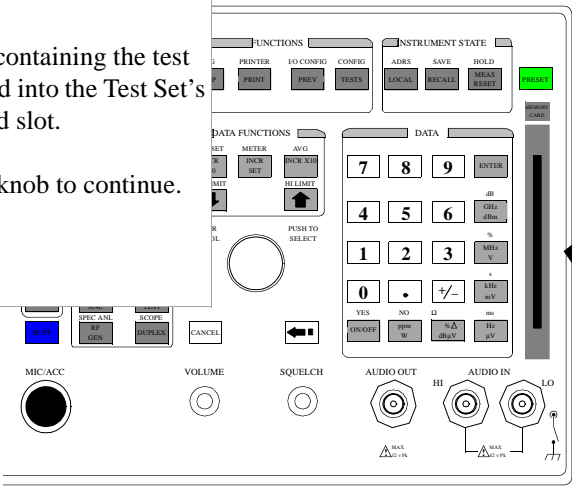

HP 8924C/E

HP E8285A

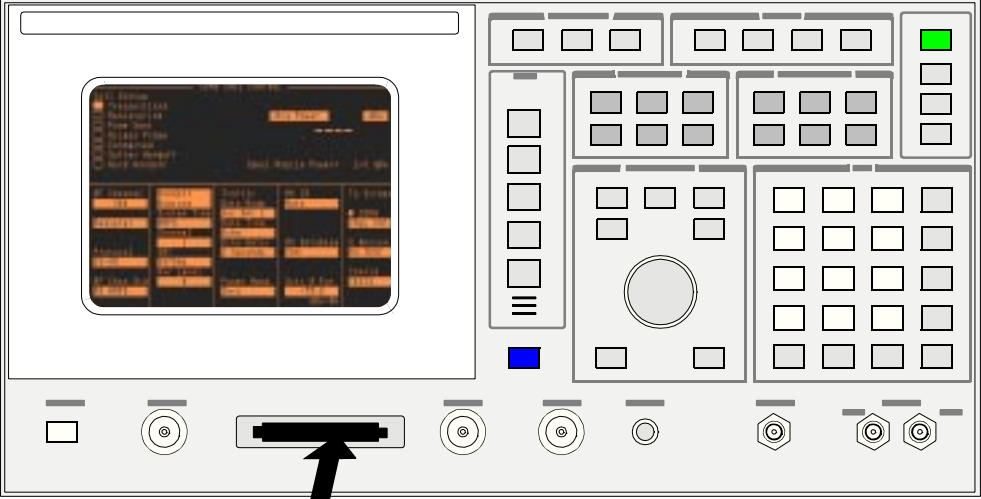

TESTS (IBASIC Controller)

	1	
	2	
	3	
	4	
	5	
To Screen		
<input type="radio"/> CDMA		
<input type="radio"/> CALL CNTL		

7. Select the test result file(s) to retrieve data from.

- a. Position the cursor next to the name of the test result file to retrieve data from and select it. An * will appear next to the file name if it is selected. More than one file can be selected.
- b. To de-select a file, position the cursor next to the name of the test result file and select it. The * will be removed.

The screenshot shows the 'TESTS (IBASIC Controller)' menu. At the top, there are five numbered options: 1 Run, 2 Continue, 3 Sngl Step, 4 Clr Scr, and 5 Main Menu. Below these is a 'To Screen' section with radio buttons for 'CDMA' and 'Analog', and buttons for 'CALL CNTL' and 'RX TEST'. The main menu area contains instructions: '1. Use the knob to select the files to transfer.', '2. Select an Output Port.', and '3. Select Start Transfer.' Below these instructions is a dashed line separator, followed by 'Output Port = Serial Port, 9600', 'Start Transfer', and 'Exit Data-Collection-File-Transfer'. Another dashed line separator follows. Below this, there is a list of 'Test Result Filename*' entries, with the first one having a small black square next to it. A white arrow with a black outline points to this first entry. The title 'TESTS (IBASIC Controller)' is centered at the top of the menu area.

8. Select the output port to send the retrieved data to.

- a. Position the cursor next to the **Output Port** field.
- b. Push the cursor-control knob to select the Test Set's output port to send the retrieved data to. Pushing the cursor-control knob toggles the output port's setting. The choices are:

Serial Port, 9600 Baud
HPIB, Addr 701

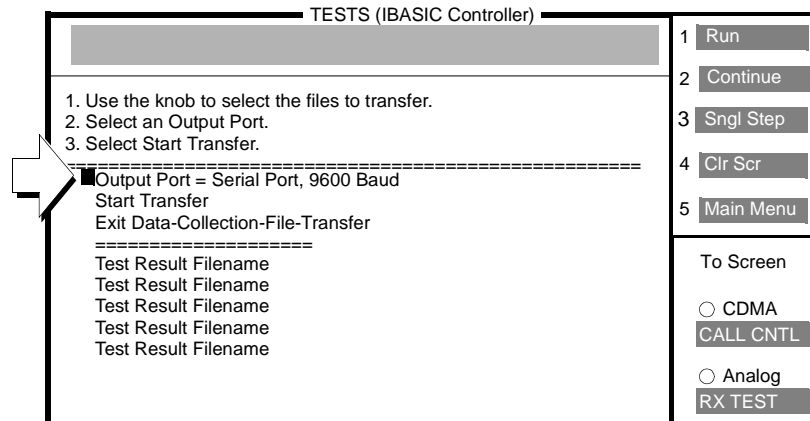

9. Send the retrieved data to the selected output port.

- a. Position the cursor next to the **Start Transfer** field and select it. The selected data file(s) will be opened and the test result data sent to the selected output port.
- b. The message **SENDING DATA** will be displayed while the data is being sent to the selected output port.
- c. When the data transfer is completed the **Continue** message will be displayed in the lower-left corner of the screen. Push the cursor-control knob to return to the main menu.

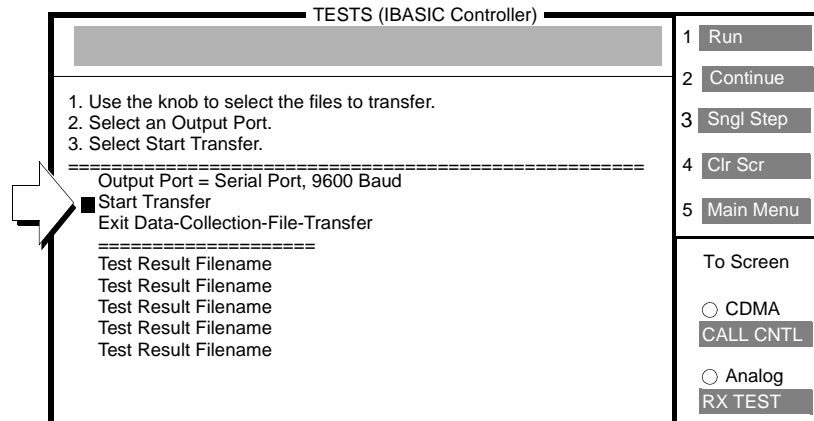

10. Exit the utility program.

- a. Position the cursor next to the **Exit-Data-Collection-File-Transfer** field and select it.
- b. Position the cursor next to the **EXIT** field and select it.
- c. The utility program is terminated.

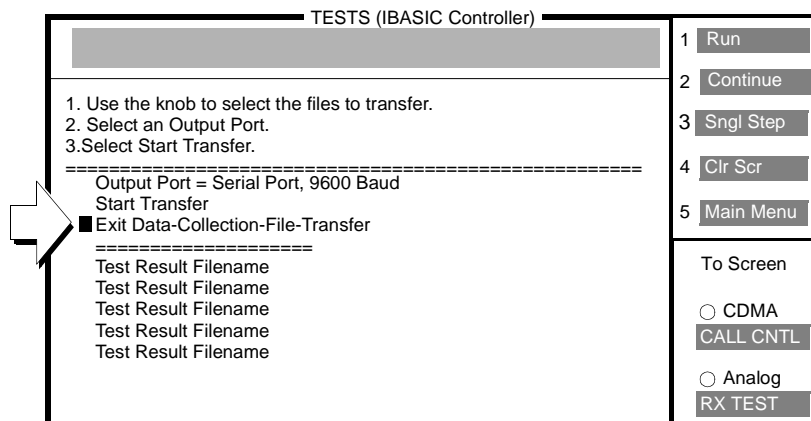

To Initialize a Memory Card (DOS Format)

Initializing PCMCIA SRAM cards using the TESTS (Save/Delete Procedure) screen automatically defaults to the recommended file system for data collection (DOS format). See ["File Types and Sizes" on page 184](#).

The [following procedure](#) shows how to initialize a PCMCIA SRAM card with a DOS format.

1. Activate the Tests Subsystem.

a. Press the TESTS key.

HP 8924C/E

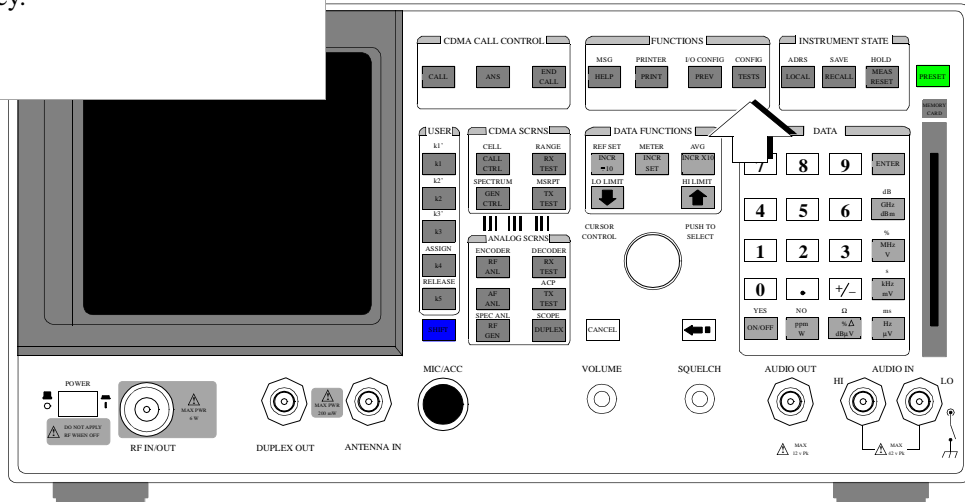

HP E8285A

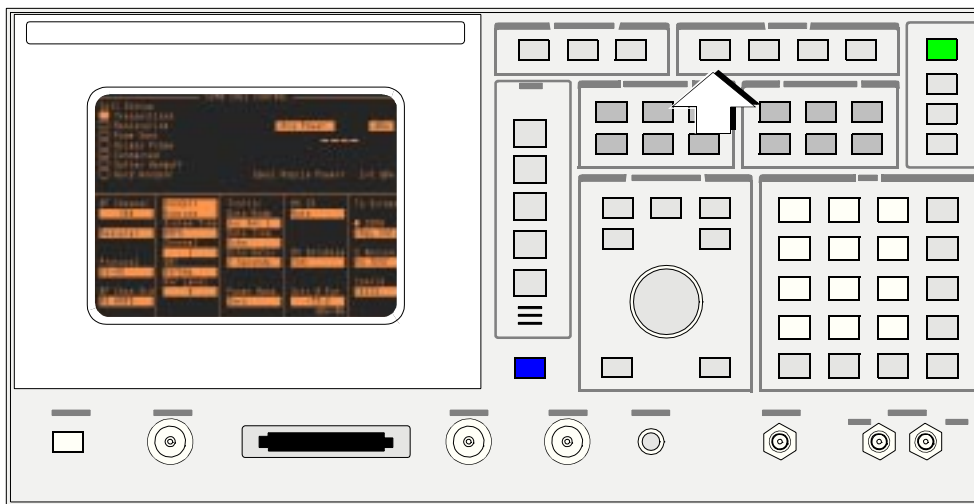

2. Select the screen for initializing an SRAM memory card (DOS format).

a. Position the cursor at the **Save/Delete Procedure** field and select it.

b. Verify that the TESTS (Save/Delete Procedure) screen appears.

TESTS (Main Menu)

P 83217A Software Name

TEST PROCEDURE:
 Procedure Location: Procedure Filename: Library: Program:

Description:

CUSTOMIZE TEST PROCEDURE: SET UP TEST SET:

<table border="0"> <tr><td style="border: 1px solid gray; padding: 2px;">Freq</td><td>Channel Information</td></tr> <tr><td style="border: 1px solid gray; padding: 2px;">Parm</td><td>Test Parameters</td></tr> <tr><td style="border: 1px solid gray; padding: 2px;">Seqn</td><td>Order of Tests</td></tr> <tr><td style="border: 1px solid gray; padding: 2px;">Spec</td><td>Pass/Fail Limits</td></tr> <tr><td style="border: 1px solid gray; padding: 2px;">Proc</td><td>Save/Delete Procedure</td></tr> </table>	Freq	Channel Information	Parm	Test Parameters	Seqn	Order of Tests	Spec	Pass/Fail Limits	Proc	Save/Delete Procedure	<table border="0"> <tr><td style="border: 1px solid gray; padding: 2px;">Exec</td><td>Execution Cond</td></tr> <tr><td style="border: 1px solid gray; padding: 2px;">Cnfg</td><td>External Devices</td></tr> <tr><td style="border: 1px solid gray; padding: 2px;">Print</td><td>Printer Setup</td></tr> <tr><td style="border: 1px solid gray; padding: 2px;">IBASIC</td><td>IBASIC Cntrl</td></tr> </table>	Exec	Execution Cond	Cnfg	External Devices	Print	Printer Setup	IBASIC	IBASIC Cntrl
Freq	Channel Information																		
Parm	Test Parameters																		
Seqn	Order of Tests																		
Spec	Pass/Fail Limits																		
Proc	Save/Delete Procedure																		
Exec	Execution Cond																		
Cnfg	External Devices																		
Print	Printer Setup																		
IBASIC	IBASIC Cntrl																		

TESTS (Save/Delete Procedures)

SAVE/DELETE TEST PROCEDURE:

Select Procedure Location:

Enter Procedure Filename:

Enter Description for New Procedure:

SAVE PROCEDURE INFORMATION:

Procedure Library:

Code Location:

Password

1

2

3

4

5

To Screen

CDMA
 CALL CNTL

Analog
 RX TEST

Config
 TESTS

3. Insert an SRAM memory card into the MEMORY CARD slot.

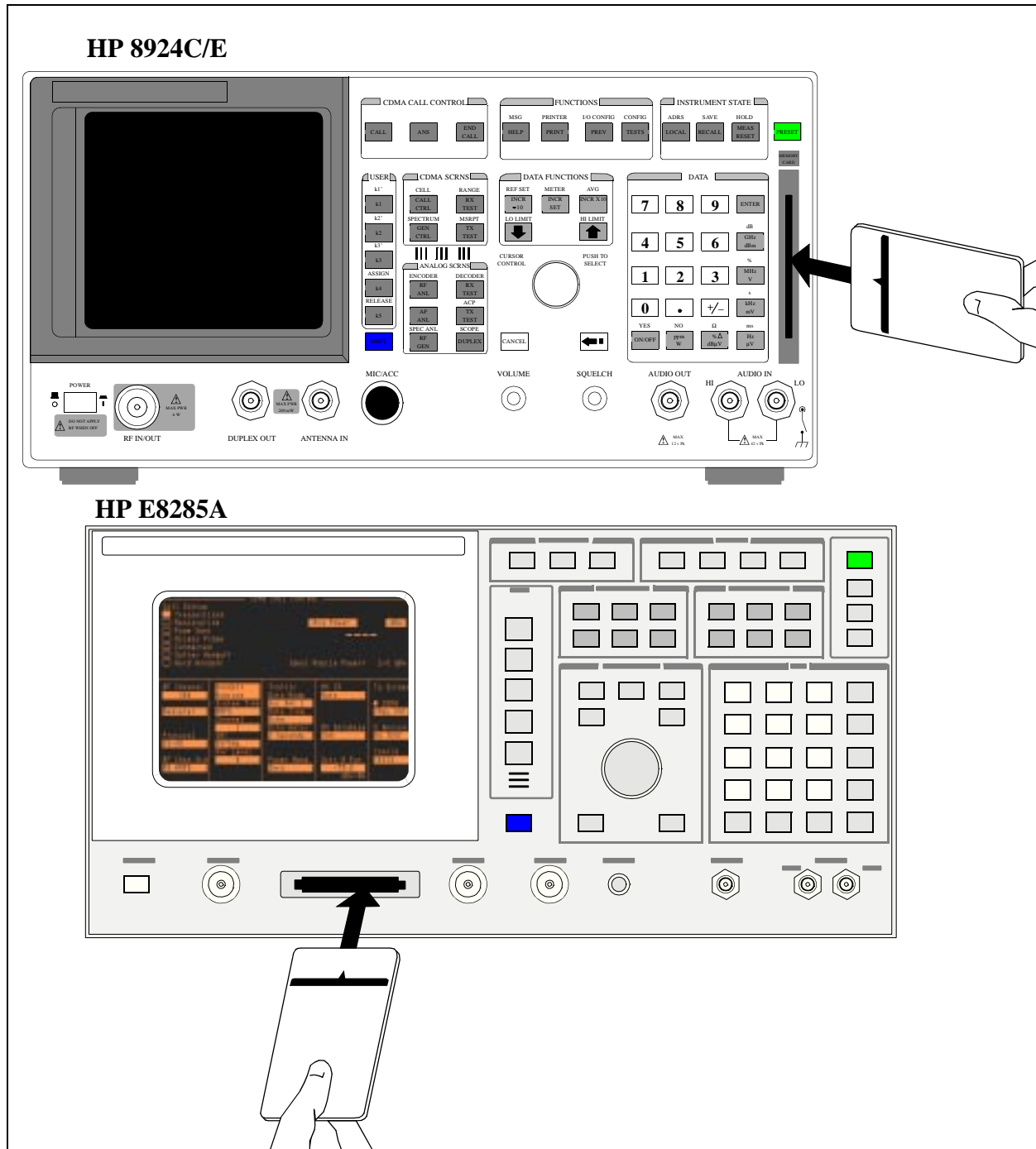

4. Initialize the memory card.

- a. Press K3 (**Init Card**) softkey.
- b. Follow instructions on the screen.

TESTS (Save/Delete Procedures)

SAVE/DELETE TEST PROCEDURE:

Select Procedure Location:
Card

Enter Procedure Filename:
[Redacted]

Enter Description for New Procedure:
[Redacted]

SAVE PROCEDURE INFORMATION:

Procedure Library:
Current/[No Lib]

Code Location:
Card

1 Save Proc
2 Del Proc
3 Init Card
4 Help
5 Main Menu

To Screen

CDMA
CALL CNTL

Analog
RX TEST

To Initialize a Memory Card (LIF Format)

NOTE:

LIF format is not recommended for data collection because no extensible files can be created. This requires the user to know, in advance, how much file space will be required and to create the proper file size. See "[File Types and Sizes](#)" on page 184 for further information.

A PCMCIA SRAM card can be initialized with a LIF format by entering an IBASIC command into the IBASIC Controller Command Line.

The [following procedure](#) shows how to initialize a PCMCIA SRAM card with a LIF format.

1. Activate the Tests Subsystem.

a. Press the TESTS key.

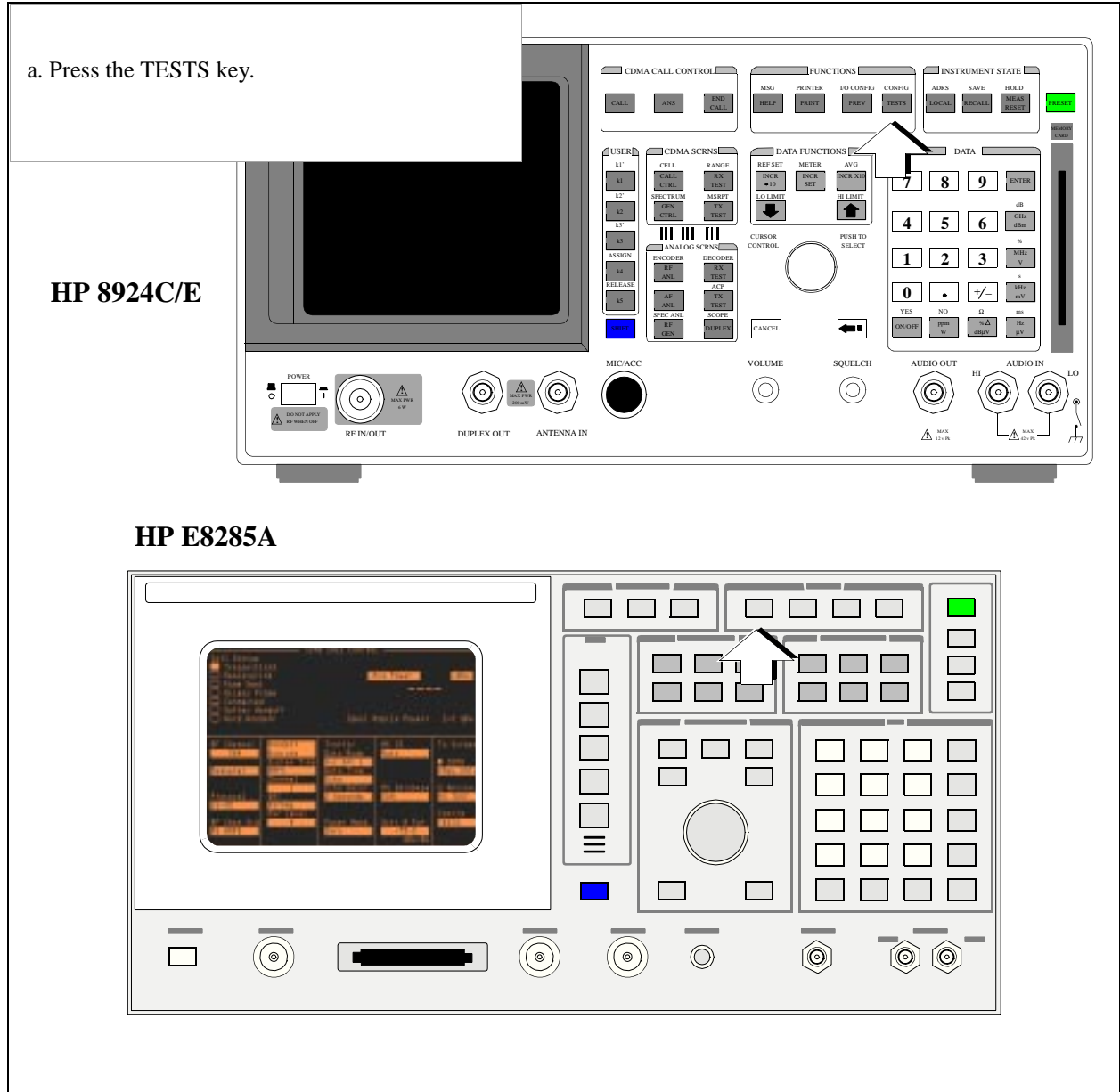

2. Select the screen for initializing an SRAM memory card (LIF format).

a. Position the cursor at the **IBASIC Cntrl** field and select it.

b. Verify that the TESTS (IBASIC Controller) screen appears.

TESTS (Main Menu)

P 83217A Software Name

TEST PROCEDURE:
 Procedure Location:
 Procedure Filename: Library: Program:

Description:

CUSTOMIZE TEST PROCEDURE: SET UP Test Set:

Freq	Channel Information	Exec	Execution Cond
Parm	Test Parameters	Cnfg	External Devices
Seqn	Order of Tests	Print	Printer Setup
Spec	Pass/Fail Limits	IBASIC	IBASIC Cntrl
Proc	Save/Delete Procedure		

TESTS (IBASIC Controller)

1 Run

2 Continue

3 Sngl Step

4 Clr Scr

5 Main Menu

To Screen

CDMA
CALL CNTL

Analog
RX TEST

Config
TESTS

174

S:\HP83217A\USRGUIDE\BOOK\Chapters\5datac.fb

3. Insert an SRAM memory card into the MEMORY CARD slot.

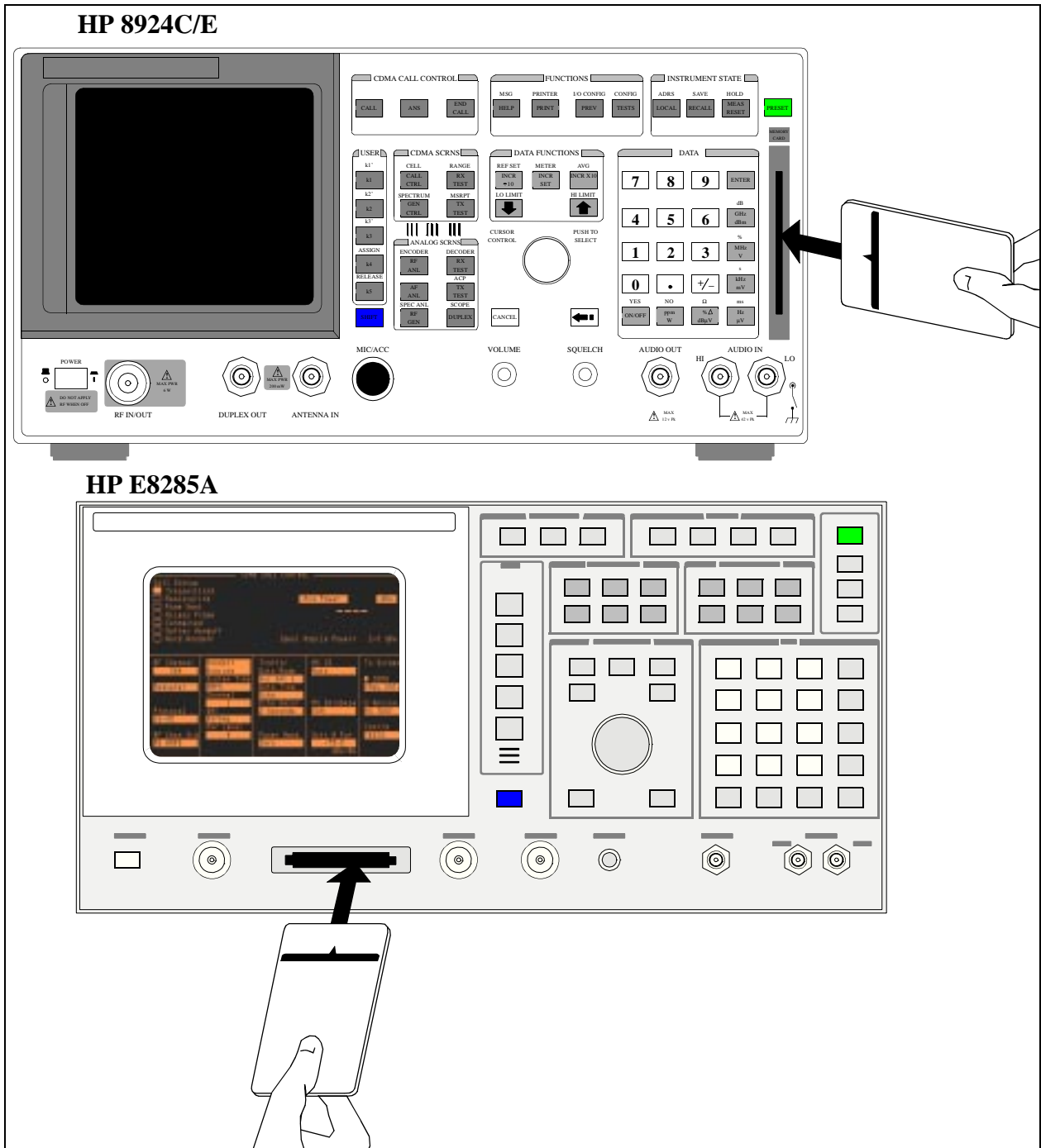

4. Initialize the memory card.

- a. Position the cursor at the IBASIC command line and select it.
- b. Using either a PC, terminal, or the character list that appears in the Choices menu, enter the following command:

```
INITIALIZE ":INTERNAL"
```

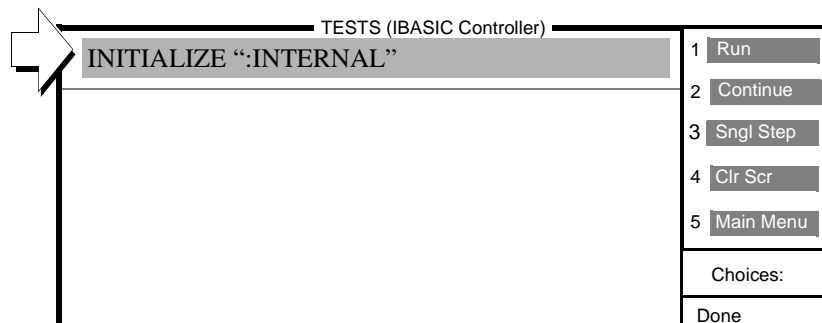

Test Set Overview

This chapter will acquaint you with the Test Set's front panel and the TESTS (Main Menu) screen. The TESTS (Main Menu) screen is the starting place for running and loading the software.

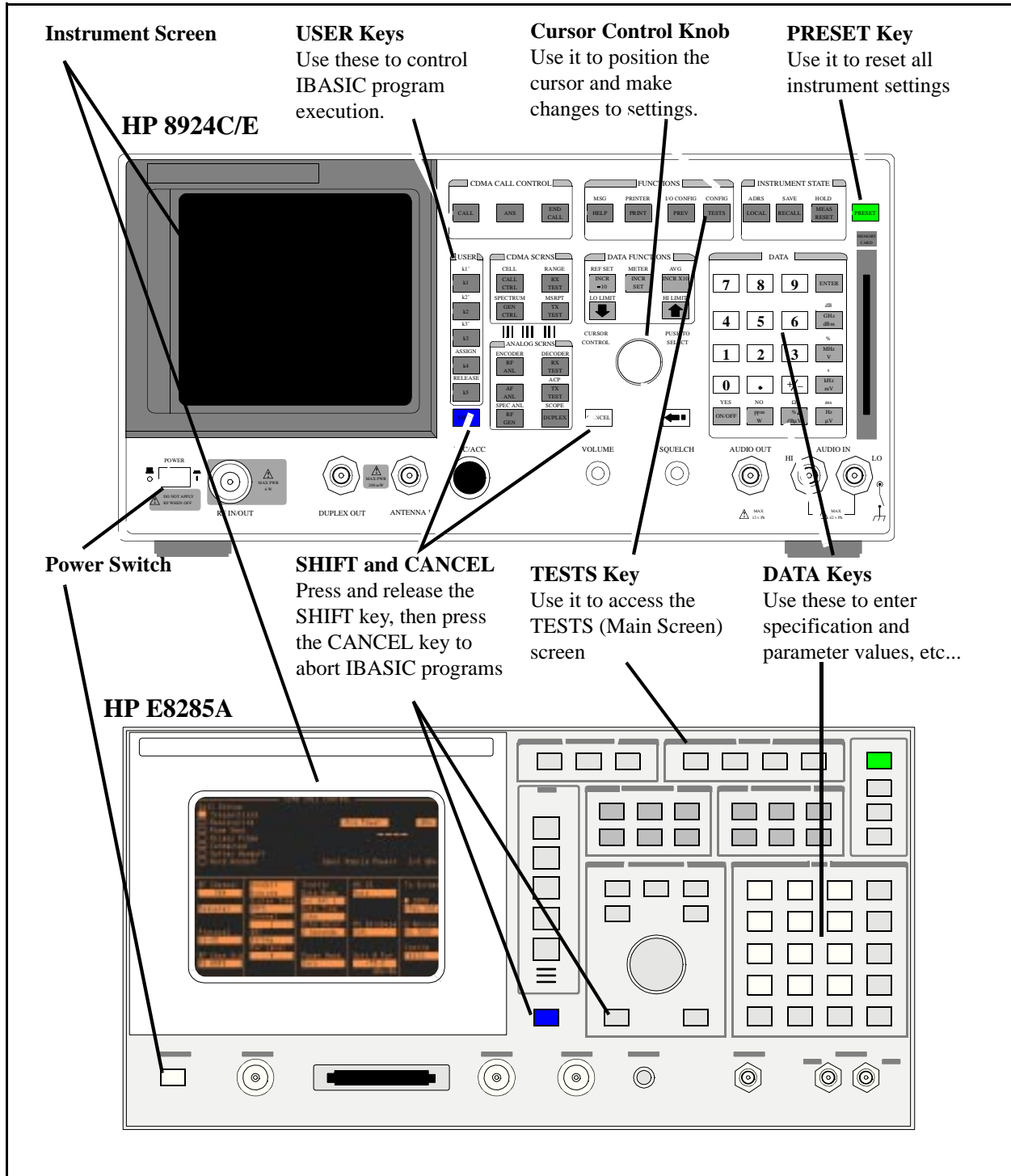

TESTS (Main Menu) Screen Overview

TESTS (Main Menu)																					
Please select a procedure to load.																					
<p>LOAD TEST PROCEDURE: Select Procedure Location: Select Procedure Filename: Library: Program: Description:</p>																					
<p>CUSTOMIZE TEST PROCEDURE: SET UP TEST SET:</p> <table border="0"> <tr> <td>Freq</td> <td>Channel Information</td> <td>Exec</td> <td>Execution Cond</td> </tr> <tr> <td>Parm</td> <td>Test Parameters</td> <td>Cnfg</td> <td>External Devices</td> </tr> <tr> <td>Seqn</td> <td>Order of Tests</td> <td>Print</td> <td>Printer Setup</td> </tr> <tr> <td>Spec</td> <td>Pass/Fail Limits</td> <td>IBASIC</td> <td>IBASIC Cntrl</td> </tr> <tr> <td>Proc</td> <td>Save/Delete Procedure</td> <td></td> <td></td> </tr> </table>		Freq	Channel Information	Exec	Execution Cond	Parm	Test Parameters	Cnfg	External Devices	Seqn	Order of Tests	Print	Printer Setup	Spec	Pass/Fail Limits	IBASIC	IBASIC Cntrl	Proc	Save/Delete Procedure		
Freq	Channel Information	Exec	Execution Cond																		
Parm	Test Parameters	Cnfg	External Devices																		
Seqn	Order of Tests	Print	Printer Setup																		
Spec	Pass/Fail Limits	IBASIC	IBASIC Cntrl																		
Proc	Save/Delete Procedure																				
1	Run Test																				
2	Continue																				
4	Help																				
To Screen																					
	<input type="radio"/> CDMA																				
	CALL CNTL																				
	<input type="radio"/> Analog																				
	RX TEST																				
	<input type="radio"/> Config																				
	TESTS																				

LOAD TEST PROCEDURE: Field Descriptions

Select Procedure Location:

This field is used to select the location of the procedure to load. Procedures can be loaded from a memory card, RAM, ROM, or Disk.

Select Procedure Filename:

This field is used to select the procedure file you want to load from the location chosen in the Select Procedure Location: field.

Description:

This field displays a description of the test procedure choose in the Select Procedure Filename: field.

CUSTOMIZE TEST PROCEDURE: Field Descriptions

Channel Information

This field is used to select the TESTS (Channel Information) screen which is used to select the frequencies to be tested.

Test Parameter

This field is used to select the TESTS (Test Parameters) screen which is used to define operating and testing characteristics to match those of the radio being tested.

Order of Tests

This field is used to select the TESTS (Order of Tests) screen which is used to select the radio tests you want to perform and the order in which the test are done.

Pass Fail Limits

This field is used to select the TESTS (Pass/Fail Limits) screen which is used to set the upper and lower limits a measurement result is checked against to determine if the UUT passed or failed.

Save/Delete Procedure

This field is used to select the TESTS (Save/Delete Procedure) screen which, after loading a test procedure and customizing channel information, parameters, order of tests and pass/fail limits, is used to save the customized test procedure for later use.

SET UP TEST SET: Field Descriptions

Execution Cond

This field is used to select the TESTS (Execution Conditions) screen which is used to determine how test are run.

External Devices

This field is used to select the TESTS (External Devices) screen which is used to configure external devices into the test system.

Printer Setup

This field is used to select the TESTS (Printer Setup) screen which is used to configure an external printer into the test system.

IBASIC Cntrl

This field is used to select the TESTS (IBASIC Controller) screen which is used to run IBASIC programs.

Reference (Alphabetical)

This information is related to Test Set and software operation. The topics are arranged alphabetically:

- **"Escape Sequences for HP Printers" on page 183**
- **"File Types and Sizes" on page 184**
- **"HP-IB Control Annunciators" on page 186**
- **"Interactions Between the Test?, Prime?, and All Chans? Fields" on page 187**
- **"Memory Cards" on page 190**
- **"The Tests Subsystem" on page 193**
- **"Serial Port Information" on page 196**

Escape Sequences for HP Printers

Table 6 Escape Sequence Definitions for HP Printers

Escape Sequence	Print Feature
&l66P	Sets page length to 66 lines
&l72P	Sets page length to 72 lines
&l6D	Sets lines per inch to 6 lines
&l8D	Sets lines to inch to 8 lines
(s12h12v6T	Selects 12 characters per inch Sets 12/72 inch character height gothic typeface
&a9L~&l6E	Sets left margin to 9 characters Sets top margin to 6 lines
(s12h12v6T~&a9L~&l6E	Selects 12 characters per inch Sets 12/72 inch character height gothic typeface Sets left margin to 9 characters Sets top margin to 6 lines
&l8d88P	Selects 8 lines per inch Sets 88 lines per page
&l8d96P	Selects 8 lines per inch Sets 96 lines per page
(s16.67h12V~&a17L~&l6E	Selects 16.67 characters per inch Sets 12/72 inch character height Sets left margin to 17 characters Sets top margin to 6 lines

File Types and Sizes

The software supports data storage to DOS or LIF (Logical Interchange Format) formatted media. Several file types are supported under each format as shown in [table 7](#).

Recommended File System

DOS file types under DOS formatted media is the recommended file system for data collection because DOS file types are extensible. File types that are not extensible may require the user to calculate the number of records needed to store test procedure results.

The procedure for data collection under the recommended file system is found in ["To Set Up for Data Collection" on page 146](#).

Media Formatting

["To Initialize a Memory Card \(LIF Format\)" on page 172](#) for media formatting procedures.

The Options Field

If the recommended file system for data collection is used, *no* entry is required in the **Options** field on the TESTS (External Devices) screen.

The **Options** field is used to specify three file parameters:

- file type: ASCII, BDAT or HP-UX
- file size (in number of records)
- DOS file extension: the three character extension is specified by putting it between parentheses. For example: (ext)

More than one of the three file parameters can be specified in a single options field. See [table 7](#) for **Options** field entries.

Table 7 **File Type and Size Information**

(AAA) where AAA = 3 character DOS file extension	filename: filename.AAA	Generates Error 53 Improper File Name
--	------------------------	---------------------------------------

NOTE:

The disk format is automatically determined by the Test Set's firmware.

If the quantity of data collected exceeds the size of the file, an error will be generated and the test procedure will stop.

HP-IB Control Annunciators

The words, letters, and symbols at the top right corner of the screen indicate these conditions:

- **R** indicates remote operation from an external controller or IBASIC program in the Test Set. This letter will be displayed while the software is running.
- **L** indicates that the Test Set is listening, and is ready to receive a manual or remote command.
- **T** indicates that the Test Set is talking to another HP-IB device.
- **S** indicates that a service request has been generated.
- **C** indicates that the Test Set is currently an active controller. Control mode is set on the I/O CONFIGURE screen. The Test Set must be a controller if HP-IB peripherals are to be controlled.
- ***** indicates that an IBASIC program is running, or that the IBASIC controller is executing a command.
- **?** indicates that an IBASIC program is waiting for a user response.
- **-** indicates that the IBASIC program is paused.
- **SHIFT** indicates that the SHIFT key was pressed, and that the next key entry will access the function labeled in blue above that key. (Press the SHIFT key again to clear).

Interactions Between the Test?, Prime?, and All Chans? Fields

The **All Chans?** field in the TESTS (Order of Tests) screen interacts closely with the **Prime?** field on the TESTS (Channel Information) screen. When the software runs, it begins by retrieving the first channel entered into the TESTS (Channel Information) screen. It then checks the response in the **Test?** field to determine if the UUT should be tested at that channel. If there is a **No** response in the **Test?** field, the software will go to the next channel in the table. If there is a **Yes** response in the **Test?** field, the software will check if the channel is **Prime**.

If there is a **Yes** response in the **Prime?** field, the UUT is tested at that channel for all tests in the procedure. If there is a **No** response in the **Prime?** field, the UUT is tested at that channel only when there is a **Yes** response in the **All Chans?** field. Therefore, tests with a **No** response in the **All Chans?** field will be run on *prime* channels only.

Chapter 7, Reference (Alphabetical)
Interactions Between the Test?, Prime?, and All Chans? Fields

Below is an example of how the software would run if you had a test procedure set up as follows:

TESTS (Channel Information) Screen Setup				
Entry #	Cell Channel	Options	Test?	Prime?
1	Chan 01		Yes	Yes
2	Chan 02		Yes	No
3	Chan 03	END	No	No

TESTS (Order of Tests) Screen Setup			
Step#	Test Name Description	All Chans?	Comment
1	Test 01	No	Run on prime channels only
2	Test 02	Yes	Run on prime and non-prime
3	Test 03	Yes	Run on prime and non-prime
4	Test 04	No	Run on prime channels only

The result would be:

- Test 01, Test 02, Test 03, and Test 04 are run on Chan 01.
- Test 02, and Test 03 are run on Chan 02.
- Chan 03 is not used.

The following table shows how to properly configure these settings according to your testing needs.

Testing Need	Necessary Field Settings		
	Test?	Prime?	All Chans?
Test channel on all tests in test procedure	Yes	Yes	Don't Care (Yes or No)
Test channel on a subset of tests in test procedure	Yes	No	Yes on all tests you want run on this channel
Do not test this channel now, but retain information for later use	No	Don't Care (Yes or No)	Don't Care (Yes or No)

Memory Cards

Memory cards are inserted into the slot on the Test Set's front panel. The memory card is powered by the Test Set while it is inserted.

The memory card can be removed after the program is loaded into the Test Set's memory. The program will remain in memory after a power-down/power-up cycle or until a new program is loaded. Loading a new program will replace a memory-resident program.

Memory cards are used to store or retrieve the following:

- Software code
- An HP-supplied test procedure, containing:
 - A pre-determined test sequence
 - Pre-defined test parameter values for each test in the sequence
 - Pre-defined pass/fail limit values for each test in the sequence
- A library file
- Procedures you make, optimized for your application
- Data collection files
- Channel information
- User defined keys

Memory Card Types

Static Random Access Memory (SRAM)

SRAM cards have read and write capability. They can be programmed and read with the Test Set.

An SRAM card can be used to store test results and procedures you make. The following parts can be used.

Table 8 PCMCIA SRAM Memory Card

Memory	Product
64 kilobytes	HP 83230A
256 kilobytes	HP 83233A
1 megabyte	HP 83231A

SRAM memory cards use a lithium battery (part number CR 2025 or HP part number 1420-0509). Programs and data will be retained for over one year if the memory card is stored at 25° C. The memory card is powered by the Test Set while it is inserted. Replace the battery while the memory card is inserted into a powered-up Test Set. To retain data and programs, it should be replaced annually. See the “Memory Cards/Mass Storage” chapter of the *HP 8924C User’s Guide* for battery replacement instructions. The write-protect switch on an SRAM memory card will write protect the card when it is set toward the outside of the card.

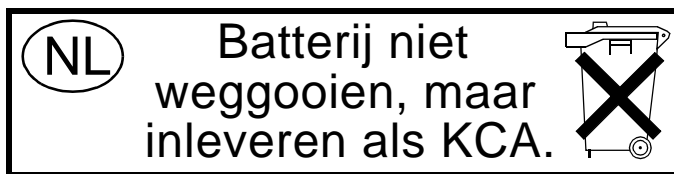

One-Time Programmable (OTP)

Once programmed with a suitable card programmer, OTP cards have read-only capability. OTP cards can be read with the Test Set, but cannot be programmed with the Test Set.

Flash Memory

Flash memory cards cannot be written to, or programmed with a Test Set, but they can be read by the Test Set.

NOTE:

Hewlett-Packard-supplied software code and Hewlett-Packard procedure and library files are typically supplied on either OTP cards or flash cards. Flash cards can be distinguished from OTP cards by a small write protect (WP) switch in the end of the flash cards. SRAM cards also have a write protect or safe switch in the end of the card, but they also have a battery slot. Software and procedure/library files stored on a flash card cannot be overwritten by a Test Set regardless of the position of the write protect (WP) switch.

Memory Card Storage Space

Use the following formula to estimate the storage space needed to save your procedures:

$$\text{Storage Space (in kilobytes)} = (\text{Number of Procedures} \times 4.1) + 20$$

For example, if you want to save ten different procedures, you will need 61 kilobytes of memory. The 64 kilobyte or 128 kilobyte card is sufficient.

The storage space you need for data collection depends on the number of test results that are saved. You will need approximately 4 kilobytes per page of test results that you save. A page of test results is about 57 lines of CRT or printer output.

The storage space of smaller SRAM cards can be quickly used. If you are collecting large quantities of data, data collection using a PC or printer may be preferable. See ["To Set Up for Data Collection" on page 146](#).

The Tests Subsystem

The Test Set is an automated user-interface which has been specifically designed for radio test. One of the primary problems associated with automated radio testing is the need to rapidly configure the software with the information needed to test a specific type of radio. Information such as, test frequencies/channels, test parameters, test conditions, and the test's pass/fail limits. Most often the tests and test procedures used to test a class of radio (AM, FM, AMPS, TACS, TDMA, CDMA, and so forth) are defined by an industry standard and are used to test all radio types within that class. However, for a specific radio type, the test(s) may remain the same but the information needed to test the radio changes. For example, a portable hand-held may have different transmit power levels than a mobile - the RF power test is the same but the power levels, supply voltages, pass/fail limits can be different.

Hewlett-Packard has developed software specifically designed to run on the Test Set. The software provides the user with a library of industry standard tests. All radio specific information has been removed from the software. The information needed to test a specific type of radio is available to the user through the Tests Subsystem. To generate, change and maintain this radio specific information the Tests Subsystem provides menu driven input screens to define specifications, parameters, test sequencing and system configuration for a particular radio type.

Tests Subsystem File Descriptions

Three types of files are used in the Tests Subsystem to store different types of information.

Code Files

One file type is the code itself. This is just a standard IBASIC Code file that can reside either on the Memory card, or in an internal RAM disk. The name of this file has a.PGM file extension.

Library Files

A Library indicates all of the available test subroutines in the code, the set of all parameters that might be entered using the user-interface screens, and all specifications that might be used by the subroutines in the code to decide if a test point passes or fails.

Only one Library is defined for each Code file. The name of this file has a.LIB file extension. Also, both the Library and Code file should have the same base name to indicate the relationship between them.

A Library is required to use the user-interface screen functions of the Tests Subsystem. If the program is simple enough that there is no need for user-input, or if all the user-input is simple enough to be accomplished with INPUT statements, a [NO LIB] option is available.

Procedure Files

A Procedure allows the user to define which of the test subroutines, parameters, and specifications defined in the Library will be used to test a specific Radio. There may be many Procedures defined that use the same IBASIC Code and Library, each using a different subset of the choices available in the Library. These files have a.PRC file extension, but are *not* required to have the same base name as either the Library or the Code. The name of the corresponding Library (if any) is stored in each Procedure file.

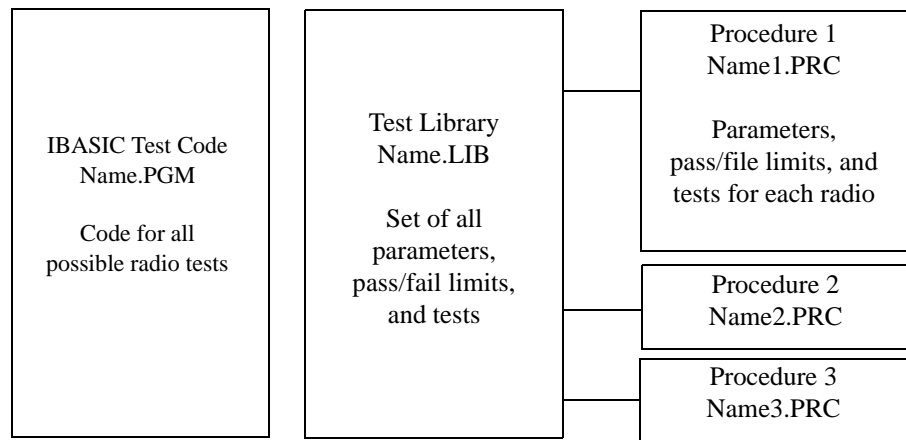

Figure 8 Tests Subsystem File Relationship

Serial Port Information

The Test Set's rear-panel serial port consists of an RJ-11 connector with 6 conductors (HP 8924C/E) or two separate 9-pin sub-miniature D connectors (HP E8285A).

In the case of the HP 8924C/E, note that the RJ-11 connector appears the same as a common 4-conductor RJ-11 telephone jack, but the Test Set's jack uses 6 conductors. Three of the wires are designated as Serial I/O Port address 9, and the other three wires are designated Serial I/O Port address 10 (also referred to as Serial Port B). The IBASIC Controller can send and receive data from either port by using its assigned select code.

Serial Port 9

Serial Port 9 is used for developing and editing IBASIC programs since it can be connected directly to the **IBASIC Command Line** field. It can also be used for data I/O from an IBASIC program. Settings can be changed from the I/O CONFIGURE screen, using IBASIC commands executed from the **IBASIC Command Line** field, or using IBASIC commands executed from an IBASIC program.

Serial Port 10

Serial Port 10 is primarily used for data I/O from an IBASIC program to a device-under-test- (DUT). Settings can be changed using IBASIC commands executed from the **IBASIC Command Line** field, or using IBASIC commands executed from an IBASIC program but not from the I/O CONFIGURE screen.

USER Keys (K1-K5)

When you are using the Test Set, you will see the following USER keys appear in the top-right corner of the display. These keys are assigned to the front-panel keys K1 through K5. In many cases, these keys can be used as “shortcuts” instead of positioning the cursor and selecting. USER keys are sometimes referred to as softkeys.

Clr scr clears the Test Set’s display.

Continue continues the program after it has been paused.

Delet stp is used to edit items in a test sequence. When you press this key, the test in the displayed sequence that has its **step #** highlighted (inverse video) will be deleted. The tests that follow in the sequence will be scrolled up by one step.

Delet Proc is used to delete the selected procedure. When you press this key, you will be prompted to verify the command by pressing the YES key.

Select **Done** when you want to exit a test or have completed a task. The program will continue if there is a next test in the sequence or if there are additional program steps in the test being run.

Help provides information on how to use the current TEST screen.

Init Card is used to initialize a memory card. Before you press this key, verify that the card is inserted correctly and that it is not in the write-protected position.

Insrt Step is used to enter items into a test sequence. When you press this key, the test in the displayed sequence that has its **Step #** highlighted (inverse video) will be copied into a new sequence location, immediately after the highlighted one. The tests that follow in the sequence will be scrolled down by one step. This key does nothing if there are no items in the sequence. Choose a test before using this key to insert another.

Main Menu is used to return to the main TESTS screen. The same result is achieved by pressing the TESTS key.

Page Up, Page Down are used to quickly display items in the list when some of the items won't fit on the screen.

Run starts an IBASIC program that has been loaded into the Test Set's memory.

Run Test loads and runs the program that is called from the procedure that has been entered into the TESTS screen **Select Procedure Filename:** entry. If the program is already loaded into the Test Set's memory, it will be started.

Save Proc is used to save the specified procedure.

Sngl Step steps the IBASIC program one line at a time. This is different from **Continuous/Single Step** run mode. See "**Test Procedure Run Mode:**" on [page 41](#).

Stop Test pauses the test software.

Take It causes the program to accept the setting of an adjustment, and proceed with the program. The test, determining if the adjustment is within limits, is ceased.

Yes/No are pressed when answering questions displayed on the Test Set's display.

Problem Solving

This descriptions are of commonly occurring problems. The following problems are described with possible causes and corrections given.

- **"Data Collection Is Not Working" on page 200**
- **"Test Procedure Won't Run" on page 201**
- **"Test Results are Unexpected" on page 202**

Data Collection Is Not Working

- Check that you have initialized the data collection mass storage media. "**To Initialize a Memory Card (DOS Format)**" on page 167, and "**To Initialize a Memory Card (LIF Format)**" on page 172.
- Check the Test Set to make sure it's in the controller mode *if you are using an external disk drive*. See "**1a. If an external disk drive is used, put the Test Set in control mode.**" on page 147
- Check the HP-IB to make sure another (external) computer is not also an active controller.

NOTE:

When the test operator is prompted to enter a file name where data is to be stored, the protocol for the mass-storage device being used must be followed.

Test Procedure Won't Run

- ❑ Make sure the code file for your test procedure is loaded. The code file is loaded when the test procedure is run. (**Error 56 File name is undefined** will be displayed if a code file is not loaded). See ["To Run a Test Procedure" on page 25](#).
- ❑ Check the TESTS (Execution Conditions) screen. If the **If Unit-Under-Test Fails:** field is set to **Stop**, the test procedure will stop after a test fails. Press USER key K2 to continue. See ["If Unit-Under-Test Fails:" on page 40](#).
- ❑ Check the TESTS (Execution Conditions) screen. If the **Test Procedure Run Mode:** field is set to **Single Step**, press USER key K2 to continue. See ["Test Procedure Run Mode:" on page 41](#).

Test Results are Unexpected

If one or more tests fail unexpectedly, it is possible that instrument settings were changed while an IBASIC program was paused. If you need to pause a test procedure to check an instrument setting, be careful not to change instrument settings. The IBASIC program will not reconfigure the settings when continue is executed. See "[To Exit and Re-enter a Test Procedure](#)" on page 30.

Error Messages

This chapter contains error message descriptions that provide a brief description of the message as well as possible corrective actions.

NOTE:

If the Test Set displays an error that states **One or more self-tests failed**, you have a hardware problem. In this case, refer to the Test Set *Assembly Level Repair* manual.

Error Messages Overview

Many error messages are coded into the Test Set's firmware and test software. If the problem is related to Test Set operation, access the **MESSAGE** screen to see any messages that have occurred since the instrument was turned on. To do this, press and release the **SHIFT** key, then press the **HELP** key.

Many of the [error messages](#) are listed on the following pages, alphabetically, with a description of the problem and possible corrections. If you see a message that is not described here, press the **CANCEL** key, and then the **MSSG** key. Other related error messages may be displayed.

For a listing of additional error messages, see the "Error Messages" chapter in the *HP 8924C User's Guide*.

Drop power can not be measured since there is no spectrum analyzer & DUP/ANT ports are being used.

This message is displayed at TEST 04 if the test software is Option 001, and the test software is being run on an HP 8924E test set, and the test set does not include a spectrum analyzer (hardware option 012), and parameter 22 is set to 1.

Duplicate file. Over-write old file?

A file name can only be used once. The entered file name has the same name as one that is already stored on the storage media. If you answer Yes to **Over-write old file?**, the old file will be overwritten. Once an old file is overwritten, it is unretrievable. There is no backup.

Error in channel. Re-enter Cell Channel number.

Channel entries must be in the range 1 through 1023.

- Enter channel numbers into the **Cell Channel** field on the TESTS (Channel Information) screen.

ERROR 59 End of file or buffer found.

This message occurs when the record size entered into the **Options** field is too small.

ERROR 80 in (line number) Medium changed or not in drive.

This message is displayed when the Test Set is unable to load a test procedure from a memory card, is unable to access valid files from a memory card, or is unable to catalog the files from a memory card.

- Check that the card is properly inserted and has test procedure files saved on it.
- Check that the card is properly inserted and has valid files saved on it.

More Error Messages

Error in data collection information on cnfg screen. Program terminated.

This message is displayed if the file type, record size or DOS file extension information is not properly entered into the **Options** field on the TESTS (External Devices) screen.

For additional information, see [chapter 5, "Setting Up the Test Set for Data Collection"](#).

Power can not be measured since there is no spectrum analyzer & DUP/ANT ports are being used.

This message is displayed at TEST 04 if the test software is Option 001, and the test software is being run on an HP 8924E test set, and the test set does not include a spectrum analyzer (hardware option 012), and parameter 22 is set to 1.

The 'CPD Softer Handoff' test can not be run on the HP 8924E. There is no sector B. Test aborted.

This message is displayed at TEST 40 if the test software is either Option 001 or Option 004 and the test software is being run on an HP 8924E test set.

The HP 8924 must be configured in Control Mode. No other controllers may be on the HP-IB bus. Do you want to put the HP 8924 in Control Mode? Select desired softkey.

The Test Set can be set to operate as the HP-IB system controller (**Control**) or as just a talker/listener (**Talk&Lstn**). This selection is made on the Test Set's I/O CONFIGURE screen. If the TESTS (External Devices) screen has entries that require the Test Set to operate as system controller, the software will verify that the Test Set is configured properly. Select the **Yes** softkey if you wish to have the entry on the I/O CONFIGURE screen changed. If you select the **No** softkey the Test Set will not control any external devices on the HP-IB.

The ‘TXD CDMA Spectrum Emissions’ test requires a spectrum analyzer option. Test aborted.

This message is displayed at TEST 43 if the test software is either Option 001 or Option 004, and the test software is being run on an HP 8924E test set with no spectrum analyzer (hardware option 012).

Timeout error from an external instrument.

This message will be displayed if the Test Set tries to control a device on the HP-IB bus and is unable to do so within 5 seconds.

- Check cables.
- Verify that the HP-IB address and other setup conditions of your device are set properly.
- Verify entries made to the TESTS (External Devices) screen are correct.

Timeout from printer at address (printer address). Retry?

This message will be displayed if the Test Set tries to control an external printer and is unable to do so within 10 seconds. Select the **Yes** softkey if you wish to have the Test Set try again or select the **No** softkey to abort printing.

- Check the cable and the connections.
- Verify entries made to the **TESTS (External Devices)** screen are correct.

Glossary

BPF Band-pass Filter. A filter that increasingly rejects signals as their frequency increases and decreases outside of certain cutoff frequencies. In the Test Set, audio band-pass filters are used to reduce the level of out-of-band signals during certain measurements.

CANCEL A key used to pause (stop) the IBASIC program running in the Test Set.

card Refers to the memory card containing the procedures for testing the unit-under-test.

Choices: menu Refers to a field in the lower right corner of the screen that displays several possible functions for selection.

Continue Proceed with the IBASIC software program if it has been paused.

cursor Refers to the brightened region of the screen used to indicate the field/function currently being accessed.

Del Step A function to delete a step in a test procedure.

ESD ElectroStatic Discharge - A transfer of electric charge from one place to another. Devices can be damaged by the energy transferred during the discharge.

field An area on the Test Set screen with an inverse video display where entries can be made.

function Refers to a particular field, feature, or operation of the Test Set.

GN Abbreviation for General. GN appears in some titles in the software and indicates that it relates to the general system, as opposed to a transmitter (TX) or receiver (RX).

HELP A feature providing additional Test Set information accessed by pressing the HELP key. Help topics are listed in alphabetical order.

highlight Refers to the brightened region (cursor) of the screen used to indicate the field/function currently being accessed.

HPF High-pass Filter. A filter that increasingly passes signals as their frequency increases towards, and then is greater than, a certain cutoff frequency. In the Test Set, audio high-pass filters are used to reduce the level of low-frequency signals during certain measurements.

IBASIC Instrument BASIC is the computer language used by the Test Set's built-in controller. Software written using IBASIC can be downloaded from memory cards, external controllers or entered directly into the Test Set from the TESTS (IBASIC Controller) screen. This software is then used to control the Test Set during autotesting the unit-under-test.

initialize A memory card or disk must be formatted prior to storing data.

Glossary

key (USER keys) Keys refer to any of the push buttons on the front panel of the Test Set. The USER keys are a specific grouping of keys labeled K1 to K5 which perform the associated numbered function in the action field located in the upper right of the screen. The USER keys are user programmable.

knob The large dial used to move the cursor among the fields and choices on the screen. Pressing the knob selects the particular field or function.

K4 Help A feature providing specific information about how to use the current screen in the TESTS environment. This feature is accessed by pressing the K4 (**Help**) softkey from any TESTS screen.

library A collection of the names of all of the parameters, pass/fail limits, and tests in the test software. The test software and the Test Set's firmware use the library, test software code file, and a test procedure to run a customized application program. A library is stored as a file on a memory card or other mass storage with its associated procedure files.

location The mass storage location accessed to retrieve or save a particular testing procedure, for example, to a disk, card, RAM, or PC.

LPF Low-pass Filter. A filter that increasingly rejects signals as their frequency increases towards, and then is greater than, a certain cutoff frequency. In the Test Set, audio low-pass filters are used to reduce the level of high-frequency signals during certain measurements.

measurement A series of calculations performed on measurement data taken by the Test Set. These calculations provide a value to be compared against pass/fail limit values that verify the performance of the unit-under-test.

Main Menu The TESTS (Main Menu) screen accessed by pressing the TESTS key or K5 (**Main Menu**). Also referred to as the TESTS screen.

menu The Test Set's screen displays various tasks to be selected with the cursor-control knob or the USER keys; this display is a menu.

message The upper portion of the Test Set's screen is reserved for messages and prompts.

OTP One-Time Programmable (OTP) refers to a PCMCIA read only memory card on which code or data may only be stored once; similar to ROM. HP software for the Test Set is shipped on an OTP memory card.

parameters Entries you make for calibration data, phone characteristics, or test customization. They give you flexibility in the way you use the software. Default values for parameters are present in the software.

Glossary

pass/fail limits Pass/fail limits are the names of criteria verifying the performance of the unit-under-test. Usually, the associated measurement value must fall within the HI/LO limits of pass/fail values to verify performance of the unit-under-test. Default values in the test software have been derived from standard methods of measurement or from the unit-under-test requirements.

pause Using the CANCEL key pauses the running of IBASIC software in the Test Set and allows access to the keyboard functions. CONTINUE allows the software to proceed.

peak+/- max A detector in the Test Set that measures and computes the maximum of the absolute value of the positive and negative excursions of the measurement. For example, when an FM waveform with a +10 kHz and -9 kHz deviation is applied, 10 kHz will be displayed.

PRESET Sets the Test Set to its initial power-up state.

procedure A shortened label for test procedure. A procedure is a collection of channels, parameters, pass/fail limits, and testing order, saved in a file, that customizes the test software to a specific application. Procedures are made by editing existing channels, parameters, pass/fail limits, and testing order, and saving the resulting files to a memory card, disk or internal Test Set RAM.

prompts The upper portion of the Test Set screen is reserved for prompts and messages. The prompt directs the user to take some action. Messages give an indication of the status of the Test Set.

RAM Random Access Memory - The memory in the Test Set that is used to store program code and data. The Test Set's RAM is battery-backed-up, retaining data and program codes when the power is turned off.

ROM Read Only Memory.

Run Test Directs the Test Set to load the program for the test procedure currently loaded into the Test Set and begin testing (may take up to two minutes).

SAT Supervisory Audio Tone - A 5970 Hz, 6000 Hz, or 6030 Hz sine-wave signal that frequency modulates an AMPS cell-site voice-channel transmitter. The signal is transponded by the mobile station and is used to help determine RF path integrity.

save Save and store are used synonymously and refer to putting data or software on some mass storage device, such as, card or RAM.

screen Refers to the video display of the Test Set.

select To choose a particular field or function. Rotate the CURSOR CONTROL knob and position the highlighted cursor on the chosen field or function, then press the knob. An alternative method is to press the numbered USER key having the same number as displayed alongside the desired function.

sequence The method used in the Test Set to run one or more tests in a desired order. A sequence is entered using the TESTS (Order of Tests) screen.

Glossary

SINAD Signal plus Noise And Distortion divided by noise and distortion. A measurement that determines the quality of an audio tone in the presence of noise and distortion. A 12-dB SINAD value is often used when measuring the receiver sensitivity.

softkey The name of the set of keys next to the screen that can be assigned to certain special actions or fields. The keys are also called USER keys.

specifications Specifications are the names of criteria verifying the performance of the unit-under-test. The specification value may be changed by using the TESTS (Pass/Fail Limits) screen. Usually the associated measurement value must fall within the HI/LO limits of specification values to verify performance of the unit-under-test. Default values in the test software have been derived from standard methods of measurements.

SRAM Static Random Access Memory - A data storage device. PCMCIA SRAM memory cards can be used with the Test Set to save programs and test results.

Step# Orders the sequence of tests, e.g. Step #1 may be Test_5, and Step #2 may be Test_26 and so on.

store Store and save are used synonymously and refer to putting data or software on some mass storage device, such as card, RAM.

test A test is a collection of measurements (or a series of other tests) which verify a particular specification value or operation of the UUT. A sequence of tests are contained in a test procedure.

TESTS (Channel Information) Title of a Test Set screen that allows you to edit the values of the test frequencies.

TESTS (External Devices) Title of a Test Set screen that allows you to set up (configure) printers, PCs, disks...

TESTS (Main Menu) The screen accessed by pressing the TESTS key. It is used to customize and execute (run) all automated testing. Also referred to as the "Main Menu".

TESTS (Order of Tests) Title of a Test Set screen that allows you to change the order of tests (add or delete) in a test procedure.

TESTS (Pass/Fail Limits) Title of a Test Set screen that allows you to edit the limits of the test specifications. See also "specifications".

TESTS (Test Parameters) Title of a Test Set screen that allows you to edit the values of the test parameters. See also "parameters".

Glossary

USER keys A group of keys located immediately to the right of the Test Set's screen that allow the user to more rapidly select certain functions without rotating and pressing the knob. These key assignments are displayed in the upper right portion of the Test Set's screen. The number on the left of the function corresponds to the number on the user key K1 to K5.

values The scalar quantities or numbers inserted in the inverse video fields of the pass/fail limits or parameters. Units of measure (dB, inches, volts, watts, etc.) are contained in the pass/fail limits and test parameters.

Glossary

Symbols

*****, IBASIC control annunciator, 186
-, program paused annunciator, 186
?, waiting for response annunciator, 186

A

AdvanceLink, 141
All Chans?, 187
autostart
 on power-up, 42

B

battery
 memory card, 191
BPF
 definition of, 207

C

C, control mode annunciator, 186
CANCEL key
 definition of, 207
 position of, 178
 used to pause a test, 29
 used with **SHIFT** key to stop test, 29
Channel Information, 180
channel information
 choosing channels to test, 187
 general description, 44
 saving, 75
 securing, 98
channel number
 specifying, 44
Choices menu
 definition of, 207
Clr Scr, 197
code files, 194
configuration
 of Test Set for PC operation, 133
 of Test Set for terminal operation, 133
 PC (personal computer), 136
 power supply, programmable, 127
 serial port, 134
 terminal emulator, 144
connections
 AMPS mobile station, 21
 CDMA mobile station, 23
 diagram for AMPS mobile station, 22
 diagram for CDMA mobile station, 24
 equipment, 21
 parallel printer, 124
 serial printer (HP 8924C/E), 121
 serial printer (HP E8285A), 123
Continue, 197
continue
 after test is stopped, 40
 definition of, 207
 test, 29
continuous
 run mode, 41
cursor
 definition of, 207
cursor-control knob
 position of, 178

D

Data, 200
data collection
 description, 156
 troubleshooting, 200
DATA keys
 position of, 178
Del Proc, 197
Delet Step
 definition, 207
Delete Stp, 197
delete
 test procedure, 84
Description
 field description, 179
Done, 197

E

error messages, 204
ESD
 definition of, 207
Execution Cond, 180
execution conditions, 37
exit
 test, 30
External Devices, 180

F

field
definition of, [207](#)
flash memory card, [192](#)
function
definition of, [207](#)

G

GN
definition of, [207](#)

H

hardware
troubleshooting, [203](#)
Help, [197](#)
help
definition of, [207](#)
K4, definition of, [208](#)
highlight
definition of, [207](#)
HPF
definition of, [207](#)

I

IB_UTIL
utility program, 93
IBASIC
definition of, 207
IBASIC Cntrl, 180
Init Card, 198
initialize
definition of, 207
SRAM memory card (DOS format),
167
SRAM memory card (LIF format), 172
Insrt Stp, 198

K

key
definition of, 208
knob
definition of, 208
position of, 178

L

L, listening control annunciator, 186
.LIB files, 194
library
definition of, 208
files, 194
saving, 75
load
test procedure, 16
Location, 208
LPF
definition of, 208

M

Main Menu

definition of, 208

Main Menu, 198

mass storage device

troubleshooting, 200

measurement

definition of, 208

memory card

battery, 191

definition of, 207

description, 190

flash, 192

initializing (DOS format), 167

initializing (LIF format), 172

inserting, 190

OTP, 192

PCMCIA, 191

removing, 192

saving data to, 156

SRAM, 191

storage limits, 192

uses of, 190

write protect switch, 191

menu

definition of, 208

message

definition of, 208

error, 204

N

No., 198

O

Order of Tests, 180

order of tests

changing, 58

saving, 75

securing, 98

OTP memory card

definition of, 208

uses of, 192

P

Page Down, 198
Page Up, 198
parallel printer
 connecting, 124
parameters
 changing, 53
 definition of, 208
 general description, 53
 saving, 75
 securing, 98
Pass Fail Limits, 180
pass/fail limits
 changing, 68
 definition of, 209
 general description, 68
 saving, 75
 securing, 98
password, 99
pause
 between tests, 41
 definition of, 209
 test, 29
PC (personal computer)
 configuration, 136
PCMCIA memory card, 191
peak+/-max
 definition of, 209
.PGM files, 194
power supply
 programmable, configuring, 127
.PRC files, 195
preset
 definition of, 209
PRESET key
 position of, 178
Prime?, 187
print
 test results, 106
printer
 parallel, connecting, 124
 serial (HP 8924C/E), connecting, 121
 serial (HP E8285A), connecting, 123
 supported models, 109
Printer Setup, 180
problem solving, 199
procedure
 definition of, 209

 files, 195
 procedure. *See also test procedure*
 prompt
 definition of, 209

R

R, remote control annunciator, 186
RAM
 definition of, 209
recall
 test setup, 34
re-enter
 test at exit point, 30
RJ-11 connector, 121, 196
ROM
 definition of, 209
Run, 198
run
 test procedure, 25
run mode
 continuous, 41
 single step, 41
Run Test
 definition of, 209
 use of, 28
Run Test, 198

S

S, service request annunciator, 186

SAT

definition of, 209

save

channel information, 75

definition of, 209

library, 75

order of tests, 75

parameters, 75

pass/fail limits, 75

test procedure, 75

test results, 156

test setup, 33

Save Proc, 198**Save/Delete Procedure**, 180**screen**

definition of, 209

secure

channel information, 98

order of tests, 98

parameters, 98

pass/fail limits, 98

test procedure, 90

SECURE_IT

utility program, 95

select

definition of, 209

Select Procedure Filena-
me, 179**Select Procedure Loca-**
tion, 179

self test failed, 203

sequence

definition of, 209

sequence. *See order of tests*

serial port

cables and adapters for, 196

configuration, 134

input buffer length, 135

select code 10, 196

select code 9, 196

serial printer (HP 8924C/E)

connecting, 121

serial printer (HP E8285A)

connecting, 123

SHIFT key

position of, 178

SHIFT, shifted function annunciator,
186

SINAD

definition of, 210

single step

run mode, 41

Sngl Step, 198**softkey**

definition of, 210

softkey. *See also USER keys*

specifications

definition of, 210

specifications. *See pass/fail limits*

SRAM

definition of, 210

SRAM memory card

uses of, 191

Step#

definition of, 210

stop

on test failure, 40

test, 29

Stop Test, 198**store**

definition of, 210

T

T, talking annunciator, 186

terminal emulator

configuration, 144

test

definition of, 210

Test Parameter, 180**test procedure**

deleting, 84

general description, 75

running, 103

saving, 75

securing, 90

troubleshooting, 201

test results

displaying, 106

heading (title) for printout, 108

printing, 106

reporting all, 107

reporting failures, 107

saving, 156

troubleshooting, unexpected results,
202

test sequence. *See order of tests*

Test?, 187**TESTS** (Channel Information)

definition of, 210

TESTS (External Devices)

definition of, 210

TESTS (Main Menu)

definition of, 210

field descriptions, 179

TESTS (Order of Tests)

definition of, 210

TESTS (Pass/Fail Limits)

definition of, 210

TESTS (Test Parameters)

definition of, 210

TESTS key

position of, 178

tests subsystem

description, 193

file descriptions, 194

file relationships, 195

troubleshooting, 199

hardware, 203

mass storage device, 200

saving data, 200

test not running, [201](#)

U

USER keys
 definition of, [208](#), [211](#)
 description, [197](#)
 position of, [178](#)
utility program
 IB_UTIL, [93](#)
 SECURE_IT, [95](#)

V

values
 definition of, [211](#)

Y

Yes, 198